

GV-898+



99 Washington Street
Melrose, MA 02176
Fax 781-665-0780
TestEquipmentDepot.com

COLOR PATTERN GENERATOR



TABLE OF CONTENTS

1	GENERAL.....	1
1.1	Description.....	1
1.2	Specifications.....	2
2	SAFETY RULES.....	15
2.1	Generals	15
3	INSTALLATION	17
3.1	Power requirements.....	17
3.2	Installation and start-up	18
4	OPERATING INSTRUCTIONS.....	19
4.1	Description of the controls	19
4.2	Operating mode	21
4.2.1	Pattern selection	21
4.2.2	Systems configuration	24
5	DESCRIPTION OF INPUTS AND OUTPUTS	31
5.1	Composite video output (BNC)	31
5.2	Modulated RF output	31
5.3	Audio inputs and outputs	31
5.4	Video input and Blackburst output.....	31
5.5	Synchronism output, vertical pulse and horizontal pulse.....	32
5.6	R-G-B/ Y P _b P _r output.....	32
5.7	S-VHS output (ANALOG). S-VHS input (MPEG2).....	32
5.8	SCART connector (DIN EN 50049)	33
6	MAINTENANCE.....	35
6.1	Replacing the mains fuse	35
6.2	Cleaning recommendations	35
7	REMOTE CONTROL COMMANDS	37

COLOUR PATTERN GENERATOR

GV-898+

1 GENERAL

1.1 Description

The **GV-898+** colour pattern generator is used for control and measurements, maintenance and repair of TV and video equipments. Its application areas are development, quality control, TV production studios, service workshops and training.

This instrument covers the frequency range from **35 to 900 MHz**, with **Vestigial Side Band** modulation.

It generates digitally 16 basic pattern charts, which extend to 22 when pushing repeatedly the chart keys.

Colour signals can be codified in **PAL** (B/G/I/D/K/M/N systems), **NTSC** (M system) or **SECAM** (L/D/K systems).

The **GV-898+** incorporates **VITS** signals (*Vertical Interval Test Signals*) in CCIR, UK and FCC formats, **WSS** signal (*Wide Screen Signaling*) in 8 formats, **FLOP-TELETEXT** in four languages and **VPS** and **PDC** signals for four countries. All these signals are individually selectable.

It also provides a synthesised sound modulator for all the systems previously described. Besides it incorporates the **ZWEITON** stereo-dual system in B/G/D/K/M format and **NICAM** in B/G/I/L format.

It incorporates **32 memories** where different configurations may be stored for a later easy access by means of the rotary selector. All configurations may be selected through the combination of the rotary selector and three keys, visualising its contents on a graphic display.

The RF signal can be selected by channel or by frequency, in 50 kHz increments and can be attenuated in progressive steps of 1 dB. Channel/frequency and attenuation information is shown on the graphic display.

It also includes a **BLACKBURST** output (PAL and NTSC), video input and output, **SCART** connector, **S-VHS** connector, output for two fixed tones (1 kHz and 3 kHz), sound input for left and right channels with possibility of **ZWEITON** modulation, output for complete synchronism, output for vertical and horizontal pulses with polarity selectable, output for RGB or Y P_b P_r signals with possibility of adding synchronism on green or on luminance signals and It's also available a connector for remote control with the RS-232C bus.

1.2 Specifications

Video Carrier

Resolution	50 kHz
Tuning	By channels or by frequency through the rotary selector. Channel tables: CCIR, STDL, OIRT and FCC.
Storage	In any of the available 32 memories

RF Output

Output level	80 dB μ V
Attenuation	Up to 60 dB in 1 dB steps
Frequency range	37 to 865 MHz
Video modulation	AM
Polarity	Negative except in SECAM L (positive)
Modulation index	85 %
Impedance	75 Ω

VIDEO

Video input	
Impedance	75 Ω
Voltage	1 Vpp
DC component	-2 V to +2 V
Maximum DC Component	± 3 V
Polarity	White level positive
Coupling	AC with internal fixing

Video output	
Impedance	75 Ω
Voltage	1 Vpp
Polarity	White level positive
Coupling	DC
Black level	0 V \pm 0.2 V

Blackburst output	
Impedance	75 Ω
Synchronisms polarity	Negative
Level	0.45 Vpp
Connector	BNC

RGB outputs	
Impedance	75 Ω
Amplitude	0.7 Vpp
Synchronisms in G	0.3 Vpp (ON/OFF selectable)
Connector	BNC
Black level	0 V \pm 0.2 V

S-VHS

Impedance	75 Ω
Amplitude	
Luminance	1 Vpp
Chrominance	0.3 Vpp
Connector	S-VHS

Synchronisms

Polarity	Selectable
-----------------	------------

Synchronisms output, CS

Impedance	75 Ω
Amplitude	2.5 Vpp
Connector	BNC

Horizontal pulse output, H

Impedance	75 Ω
Amplitude	2.5 Vpp
Connector	BNC

Vertical pulse output, V

Impedance	75 Ω
Amplitude	2.5 Vpp
Connector	BNC

Chrominance**PAL/NTSC**

TV systems	PAL B/G/D/K/I/M/N, NTSC M
Subcarrier frequency	4.433619 MHz PAL B/G/D/K/I 3.579545 MHz NTSC M 3.575611 MHz PAL M 3.582056 MHz PAL N
Tolerance	< 4 ppm from 0 to 70°

SECAM

TV systems	B/G/L/D/K
Subcarrier frequency	F _{0R} = 4.406250 MHz F _{0B} = 4.250000 MHz

Identification pulses**Line**

Amplitude D'R	215 mV
Amplitude D'B	167 mV
Subcarrier blanking	5.6 μ s

Pattern charts

Chart n° 1

Complete chart, 4:3 format

Signals outside the circle

- Cross-hatch
18 vertical lines x 14 horizontal lines.
Background at 48 % of the white level
- Constellations on the edges in white and black

Colour signals from left to right:

- Vertical bar of R-Y not alternated ($90^\circ/90^\circ$) and B-Y = 0 (Anti-PAL)
- 2 vertical bars with R-Y signals (270° and 90°) and B-Y = 0
- 2 rectangles with the signal G-Y=0 (326° and 146°)
- 2 rectangles with the signal G-Y=0 (326° and 146°)
- 2 vertical bars with signals of B-Y (180° and 0°) and R-Y=0
- Vertical bar of B-Y alternated ($0^\circ/180^\circ$) y R-Y=0 (Anti-PAL)

Signals inside the circle

- Black rectangle over white background
Rectangle width 11.4 μ s.
- Black to white transition and from white to black with a black vertical line on the white side.
- Square signal of 250 kHz. White level amplitude is 75%
- Colour bars without white nor black (100/0/75/0)
- Mark of picture geometrical centre
- Multi-burst
0.8 / 1.8 / 2.8 / 3.8 / 4.8 MHz (B/G system)
0.8 / 1.8 / 2.8 / 3.8 / 4.8 / 5.63 MHz (D/K system)
1.5 / 2.5 / 3.5 / 4.0 / 4.5 / 5.25 MHz (I system)
0.8 / 1.8 / 2.8 / 1.8 / 0.8 MHz (SECAM)
0.5 / 1.0 / 2.0 / 3.0 / 4.0 MHz (M and N systems)
100% of the white level. Sinusoidal signals
- White and black staircase of 5 levels
- White to black transition and from black to white with one vertical white line on the black side.
- Colour transition, yellow/red/yellow

Complete chart, 16:9 format

Signals outside the central circle

- Cross-hatch
24 vertical lines x 14 horizontal lines
Background at 48% of the white level
- Constellations on the edges in white and black

- 4 white circles with a black square crossed by one horizontal and one vertical line on the four extremes of the image.

Colour signals from the left to the right:

- Vertical bar of R-Y not alternated ($90^\circ/90^\circ$) and B-Y=0 (Anti-PAL)
- 2 vertical bars with R-Y (270° and 90°) and B-Y=0 signals
- 2 rectangles with G-Y=0 (326° and 146°) signal
- 2 rectangles with G-Y=0 (326° and 146°) signal
- 2 vertical bars with B-Y (180° and 0°) and R-Y=0 signals
- Vertical bar of B-Y alternated ($0^\circ/180^\circ$) and R-Y=0 (Anti-PAL)

Signals inside the central circle

- Black rectangle over white background
- Black to white and white to black transition with one vertical black line on the white side.
- Square signal of 250 kHz. White level amplitude is 75%
- Colour bars without white nor black (100/0/75/0)
- Mark of picture geometrical centre
- Multi-burst
 - 0.8 / 1.8 / 2.8 / 3.8 / 4.8 MHz (B/G system)
 - 0.8 / 1.8 / 2.8 / 3.8 / 4.8 / 5.63 MHz (D/K system)
 - 1.5 / 2.5 / 3.5 / 4.0 / 4.5 / 5.25 MHz (I system)
 - 0.8 / 1.8 / 2.8 / 1.8 / 0.8 MHz (SECAM)
 - 0.5 / 1.0 / 2.0 / 3.0 / 4.0 MHz (M/N systems)
- 100% of the white level. Sinusoidal signals
- 5 level white and black staircase
- White to black and black to white transitions with one vertical white line on the black side.
- Colour transition, yellow/red/yellow

Chart n° 2

FuBK chart

PAL system

Signals outside the central area

- Cross-hatch
 - 19 vertical lines x 15 horizontal lines
 - Background at 25% of the white level

Signals inside the central area

From the top to the bottom

- Colour bars (100/0/75/0)
- White and black staircase of 4 levels
- Mark of picture geometrical centre

- White to black transition
- Multi-burst
1.0 / 2.0 / 3.0 MHz 100% of the white level
4.43 MHz ($f_{\text{sub-carrier}}$, G-Y=0) 50% of the white level
- White area with a black triangle
- $f_{\text{sub-carrier}}$ sawtooth
 $\pm(R-Y)$ signal starting from the 75% of white amplitude to the black level
 $+(B-Y)$ signal starting from the 75% of white amplitude to the black level
- R-Y not alternated signal and B-Y alternated signal with 75% of the white level (Anti-PAL).

SECAM system

- Colour bars (100/0/75/0)

NTSC system

- SMPTE mixture. SMPTE1, SMPTE2 and SMPTE3 signals

Chart n° 3

Colour bars

PAL and SECAM systems

- Colour bars 100/0/75/0
When colour bars key is pushed again it changes to 75/0/75/0 chart

NTSC system

- SMPTE1 colour bars
When colour bars key is pushed again it changes to 75/0/75/0 chart

Chart n° 4

VITS

B/G/L/D/K systems

- VITS line CCIR17
When chart key is pushed again it changes to VITS CCIR330 chart

I system

- VITS line ITS I
When chart key is pushed again it changes to VITS ITS II chart

NTSC system

- VITS line FCC composite
When chart key is pushed again it changes to VITS NTC-7 composite chart

Chart n° 5
PURITY

- Complete picture of red signal. When pushing the chart key successively it changes to blue signal and to green signal charts.

Chart n° 6
DEM**PAL system**

- 5 vertical bars. White level 50%
Colour signals from left to right
R-Y (90°/90°), B-Y=0.
B-Y (0°/180°), R-Y=0.
B-Y (180°/0°), R-Y=0.
R-Y (270°/270°), B-Y=0.
R-Y=0, B-Y=0.

SECAM system

- Colour bars 100/0/75/0

NTSC system

- SMPTE3 signal

Chart n° 7
Multi-burst**B/G/I/L/D/K systems**

- White bar (100%) and black.
6 blocks of 0.5 / 1.0 / 2.0 / 4.0 / 4.8 / 5.8 MHz 100% of white sinusoidal.
When the chart key is pushed again changes to VITS line CCIR18 chart

M/N system

- White bar (100%) and black
6 blocks de 0.5 / 1.0 / 2.0 / 3.0 / 3.58 / 4.2 MHz 100% of white sinusoidal.
When the chart key is pushed again changes to VITS line FCC
MULTI-BURST.

Chart n° 8

Pluge

B/G//L/D/K/N systems

From the left to the right

- One ultra-black vertical bar of an amplitude of the 2% of 416 lines
One grey vertical bar of an amplitude of the 2% of 416 lines
Four blocks of grey of 108 lines each one placed one above the other with an amplitude of the 100% / 64.2% / 28.5% and 15.7% respectively.

M systems

From the left to the right

- One ultra-black vertical bar of an amplitude of the 2% of 352 lines
One grey vertical bar of an amplitude of the 2% of 352 lines
Four blocks of grey of 88 lines each one placed one above the other, with an amplitude of the 100% / 64.2% / 28.5% and 15.7% respectively.

Chart n° 9

Sin X/X

B/G//L/D/K systems

- 6 MHz
Pedestal 125 mV

M/N systems

- 5 MHz
Pedestal 143 mV. Black and white bar in the centre

Chart n° 10

Ramp

- Starts with black (20 μ s) and increases up to white (53 μ s). The white is held until the end of the line.

Chart n° 11

Checker board, 4:3 format

- 9 white and black alternate squares in horizontal direction and 7 in vertical direction.

Chercker board, 16:9 format

- 13 white and black alternate squares in horizontal direction and 7 in vertical direction.

Chart nº 12

White

- Complete white screen (100%).

Chart nº 13

Convergence, 4:3 format

- 19 white vertical lines x 15 white horizontal lines on a black background
In the centre of each square there is a white point
A grey square (50%) on the top left side

Convergence, 16:9 format

- 25 white vertical lines x 15 white horizontal lines on a black background
In the centre of each square there is a white point
A grey square (50%) on the top left side

Chart nº 14

Window

- One white square (100%) on the centre of the screen
20 μ s of length
216 lines on B/G/I/L/D/K/N systems
194 lines on M system

Chart nº 15

Grey-scale

- 10 levels white and black staircase
When the chart key is pushed again it changes to 5 levels white and black staircase chart.

Chart nº 16

Centred

- One white horizontal line and one white vertical line indicating the geometrical centre of the picture.
- One box with white edges indicating a 10% of overscanning.
This box has three white lines on the top and on the bottom sides. The 2 external lines show dimensions in format 4:3. Two next lines show dimensions in 14:9 format with a 4:3 format image and the inner lines the 16:9 format with a 4:3 format image.

VITS signals position

- VITS signals only can be activated with those charts which have colour information.
- In the I system, signals ITS I and ITS II replace to CCIR-17, 18, 330 and 331 signals, only in charts 1 and 4.

B/G/L/D/K/N Systems	ON/OFF selectable
Line 17	CCIR-17
Line 18	CCIR-18
Line 330	CCIR-330
Line 331	CCIR-331

* In SECAM, VITS lines do not have colour information.

I System

Line 19	ITS I
Line 20	ITS II
Line 332	ITS I
Line 333	ITS II

M System

Frame 1

Line 17	FCC multi-burst
Line 18	FCC composite
Line 19	VIRS

Frame 2

Line 15	SIN X/X
Line 16	NTC-7 combination
Line 17	SMPTE 1
Line 18	NTC-7 composite
Line 19	VIRS

SOUND

Sound input

Impedance	10 k Ω
Amplitude	0.5 Vpp
Bandwidth	50 Hz to 15 kHz

Sound output

Impedance	1 k Ω
Amplitude	0.5 Vpp

MONO sound

Sound carrier 1	ON/OFF selectable and synchronized with the line frequency.
Frequency	4.5 MHz. M, N Systems 5.5 MHz. B,G Systems 6.0 MHz. I Systems 6.5 MHz. D,K,L Systems
Tolerance	< 25 ppm
Video/Audio V/A	13 dB. M, N, B, G, I Systems 11 dB. D,K,L Systems
Sound modulation	Internal External (except in NICAM)
Modulation type	AM, FM and NICAM
FM modulation	
Pre-emphasis	50 μ s. B/G/D/K/I Systems 75 μ s. M, N Systems
Internal modulation	1 kHz \pm 10 %, sinusoidal
Deviation	30 kHz \pm 2 kHz. B,G, I, D, K Systems 15 kHz \pm 5 kHz. M, N Systems
External modulation	0.5 Vpp produce the same deviation as the internal modulation.
AM modulation	
Internal modulation	1 kHz \pm 10 %, sinusoidal
Modulation index	54% \pm 4%
External modulation	0.5 Vpp produce the same deviation as the internal modulation.

DUAL, STEREO ZWEITON

2nd sound carrier	Commutable ON/OFF and synchronized with the line frequency.
Frequency	4.724212 MHz. M System 5.74218 MHz. B,G Systems 6.2578125 MHz. D,K Systems
Tolerance	<25 ppm
Video/Audio V/A	22 dB. M System 20 dB. B,G Systems 24 dB. D,K Systems
Sound modulation	Internal External
Modulation type	FM
Pre-emphasis	50 μ s. B/G/D/K Systems 75 μ s. M System
Internal modulation	3 kHz \pm 10 %, sinusoidal
Deviation	30 kHz \pm 2 kHz. B,G,D,K Systems 15 kHz \pm 5 kHz. M System
External modulation	0.5 Vpp produce the same deviation as the internal modulation.

Subcarrier	
Pilot frequency	54.6875 kHz. B/G/D/K Systems 55.069924 kHz. M System
Tolerance	<25 ppm
Modulation	AM
Modulation index	50% \pm 5%
Identification frequency	274.12 Hz DUAL B/G/D/K Systems 276.03 Hz DUAL M System 117.48 Hz ESTEREO B/G/D/K Systems 149.85 Hz ESTEREO M System
Information combination	
B/G/D/K Systems	Carrier 1: L+R, Carrier 2: 2xR
M System	Carrier 1: L+R, Carrier 2: L-R
DIGITAL SOUND (NICAM)	
Sound carrier	ON/OFF and DUAL/STEREO selectable.
Frequency	5.850 MHz in B/G/L systems 6.552 MHz in I system
Tolerance	< 10 ppm
Video / Audio (V/A)	20 dB in B/G/I systems 27 dB in L system
Modulation	4QPSK
Modes	DUAL and STEREO
Internal modulation	1 kHz and 3 kHz, selectable
Internal codification	10 bits/sample. 32 samples/block
Bit-rate	728 kbits/s
TELETEXT	
Systems	PAL B/G/I/D/K ON/OFF selectable
Frequency	6.9375 MHz
Transmission mode	NRZ (no return to zero)
Data line	From 12 to 15 and 21 in the odd fields. From 322 to 328 and 334 in the even fields.
Content	Index page and four data pages in 4 different languages.
"0" level	Black level
"1" level	66% \pm 5% of the white level
PDC (<i>Program Delivery Control</i>)	
Systems	PAL B/G/I/D/K selectable ON/OFF
Frequency	6.9375 MHz
Transmission mode	NRZ (no return to zero)
Data line	329 even frame, in a sequence of 400 ms
Content	START, STOP and PAUSE functions selectable. Country and minute selectable. Month, day and hour information are fixed to 1.
"0" level	Black level
"1" level	66% \pm 5% of the white level

VPS

Systems	PAL B/G/D/K selectable ON/OFF
Frequency	5.0 MHz
Transmission mode	Two-phase
Data line	16 odd frame
Content	Function: START, STOP and PAUSE. Country and minute selectable. Month, day and hour information are fixed to 1.
"0" level	Black level
"1" level	66% \pm 5% of the white level

WSS (Wide Screen Signaling)

Systems	PAL B/G/I/D/K selectable ON/OFF
Frequency	5.5 MHz
Transmission	Two-phase
Data line	23 odd frame
Content	Eight combinations for the following formats: 4:3, 14:9 and 16:9.
"0" level	Black level
"1" level	66% \pm 5% of the white level

COLOUR LOGOTYPE

Dimensions	Two logotypes of variable and independent dimensions. Width from 4 μ s to 45 μ s and height from 8 lines to 124 lines. They can be located inside a mark or be transparent.
Colours	6 saturated colours (blue, magenta, red, green, cyan and yellow), white and black. Black colour does not exist in transparent logotypes.
Position	They can be placed in any position of the screen, bearing in mind that 2nd logotype vertical position never can be above of 128 lines starting from 1st logotype beginning. Logotypes position is modifiable.
Format and contents	Since information is stored in an EPROM memory, they are fixed. They can be modified under request.
Resolution	476 pixels for 35 μ s logotype duration.

POWER SUPPLY

Mains voltage	110-125-220-230/240 V AC \pm 10%
Mains frequency	50-60 Hz
Consumption	40 W

OPERATING ENVIRONMENTAL CONDITIONS

Altitude	Up to 2000 m
Temperature range	From 5 °C to 40 °C
Maximum relative humidity	80% (up to 31 °C), decreasing lineally up to 50% at 40 °C.

MECHANICAL FEATURES

Dimensions	W. 288 x H. 102 x D. 307 mm
Weight	5.6 kg

INCLUDED ACCESSORIES

Mains cord, model CA-05	
--------------------------------	--

2 SAFETY RULES

2.1 Generals

- * Use this equipment connected **only to devices or systems with their common at ground potential** or insulated from the mains.
- * This is a **class I** equipment, for safety reasons plug it to a supply line with the corresponding **ground terminal**.
- * This equipment can be used in **Over-Voltage Category II** installations and **Pollution Degree 1** environments.
- * When using some of the following accessories **use only the specified ones** to ensure safety:
 - Power cord
- * Observe all **specified ratings** both of supply and measurement.
- * Remember that voltages higher than **60V DC** or **30V AC rms** are dangerous.
- * Use this instrument under the **specified environmental conditions**.
- * **The user is only authorized to** carry out the following maintenance operations:
 - Replace the mains fuse of the **specified type** and **value**.
 - On the Maintenance paragraph the proper instructions are given.
 - Any other change on the equipment should be carried out by qualified personnel.
- * **The negative of measurement** is at ground potential.
- * **Do not obstruct the ventilation system**.
- * Use for the signal inputs/outputs, specially when working with high levels, appropriate low radiation cables.
- * Follow the **cleaning instructions** described in the Maintenance paragraph.

* Symbols related with safety:



DIRECT CURRENT



ALTERNATING CURRENT



DIRECT AND ALTERNATING



GROUND TERMINAL



PROTECTIVE CONDUCTOR



FRAME TERMINAL



EQUIPOTENTIALITY



ON (Supply)



OFF (Supply)

DOUBLE INSULATION PROTECTED
(CLAS II Protection)CAUTION
(Risk of electric shock)

CAUTION REFER TO ACCOMPANYING DOCUMENTS



FUSE

3 INSTALLATION

3.1 Power requirements

This equipment requires a mains power source of 110-125-220 or 230/240 V AC 50 to 60 Hz. Mains operating voltage can be selected at the rear panel.

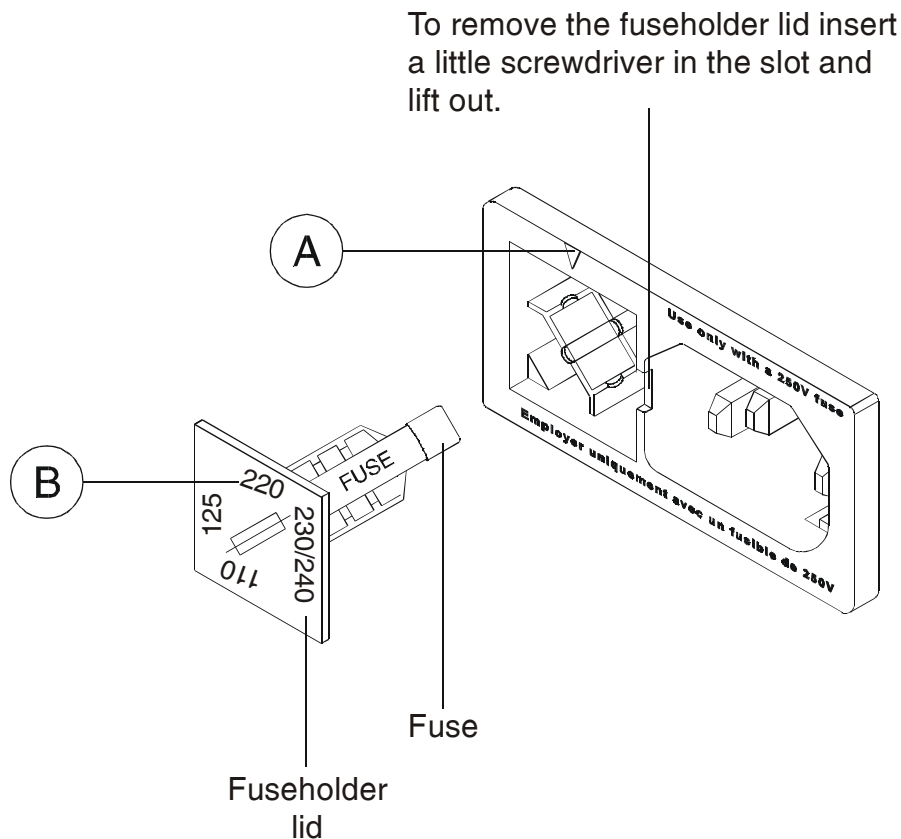

Figure 1.- Selection of mains voltage.

- 1.- Pull out the fuseholder lid.
- 2.- Set the proper fuse for the desired mains voltage.
- 3.- Insert the fuseholder lid so the [**A**] pointer faces the desired mains voltage display [**B**].

CAUTION THE EQUIPMENT IS FACTORY SET FOR 220 V OPERATING VOLTAGE.

BEFORE SWITCHING ON THIS INSTRUMENT, SET THE VOLTAGE SELECTOR TO THE PROPER POSITION AND BE SURE THAT THE FUSE VALUE IS ACCORDING TO THE MAINS VOLTAGE.

AVOIDING THIS DIRECTIONS COULD DAMAGE THE EQUIPMENT.

3.2 Installation and start-up

The equipment is prepared for use as desk top equipment.

After having selected the power supply voltage, the equipment may be connected to the mains and switched on by activating the mains switch LINE [1]; after a few seconds the LCD display will show present configuration parameters corresponding to the video and audio section, stored in memory location 00. All the outputs and inputs of the generator will remain at the state indicated on the configuration of this memory position.

The equipment's highest level of performance is obtained at about 15 minutes after switching on.

4 OPERATING INSTRUCTIONS

4.1 Description of the controls

Front Panel

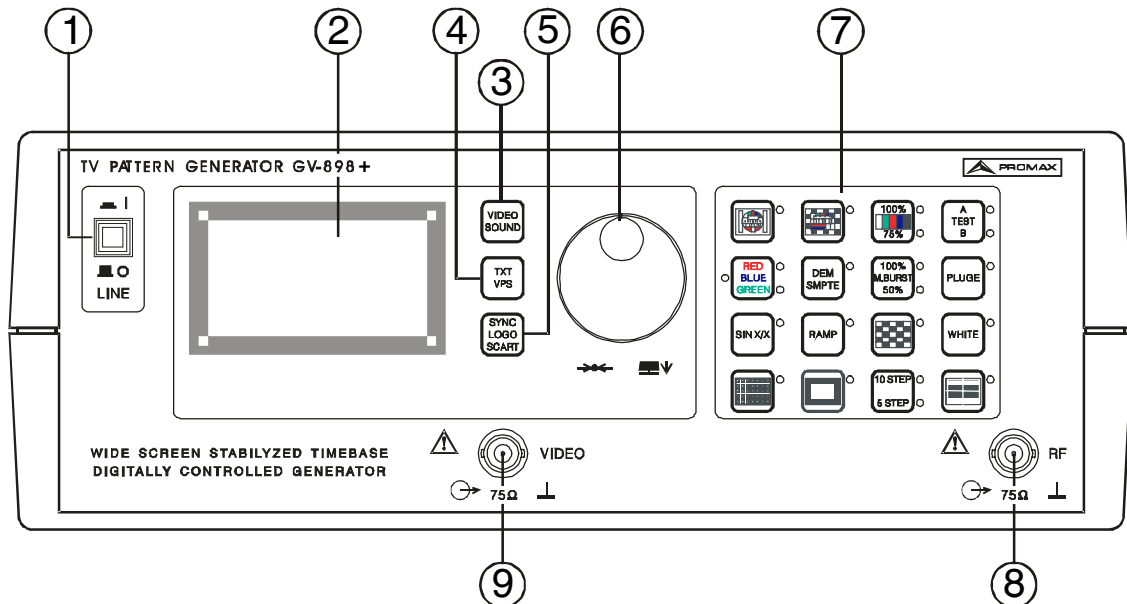
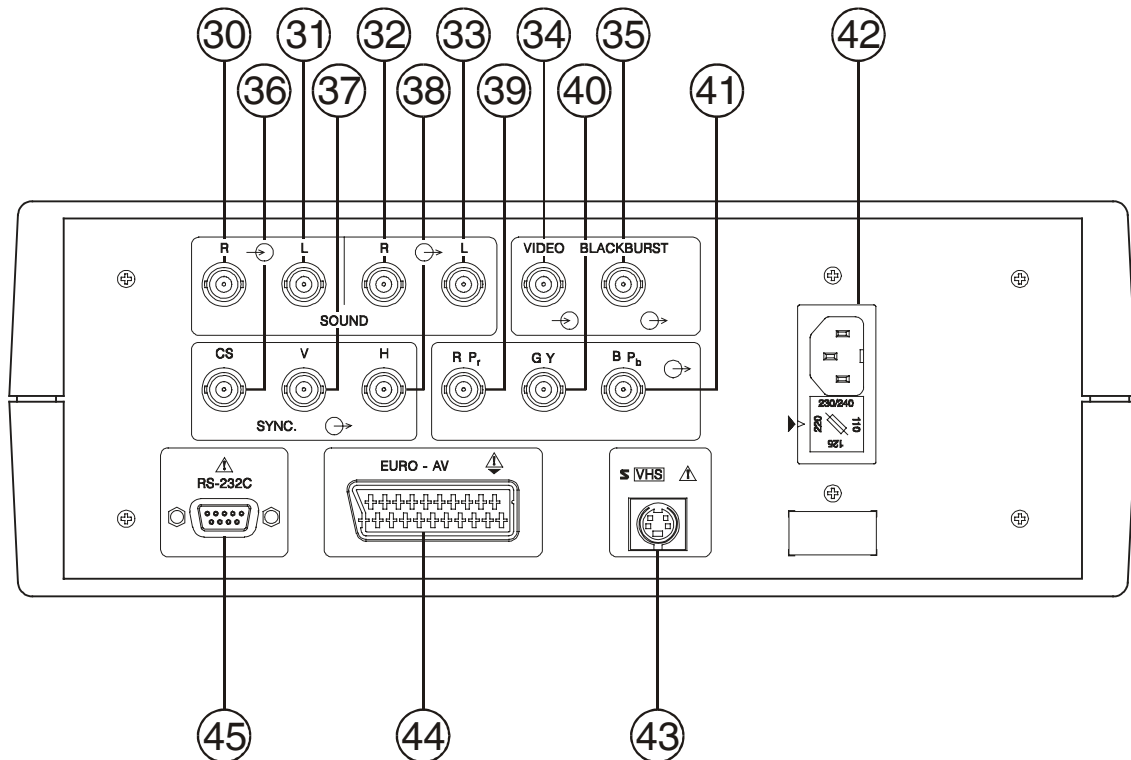

Figure 2.- Front panel

- [1] **LINE**
On/Off switch.
- [2] Configuration graphic display.
- [3] **VIDEO/SOUND**
Selecting the configuration menu referring to the video and audio signal.
- [4] **TXT, VPS**
Selection of configuration menu for teletext, and VPS and PDC signals.
- [5] **SYNC, LOGO, SCART**
Selection of configuration menu for synchronism, logos and SCART connector signals.
- [6] Rotary selector.
- [7] Pattern keyboard.
- [8] \rightarrow **RF**
RF output
- [9] \rightarrow **VIDEO**
Composite video output

Rear panel

Figure 3.- Rear panel

- [30] \ominus **R**
Right channel audio signal input.
- [31] \ominus **L**
Left channel audio signal input.
- [32] \oplus **R**
Right channel audio signal output.
- [33] \oplus **L**
Left channel audio signal output.
- [34] \ominus **VIDEO**
Exterior video input.
- [35] \oplus **BLACKBURST**
Blackburst signal output.
- [36] \oplus **CS**
CS signal output.

- [37] $\ominus \rightarrow$ **V**
Vertical pulse output.
- [38] $\ominus \rightarrow$ **H**
Horizontal pulse output.
- [39] $\ominus \rightarrow$ **R P_r**
R or P_r signal output according to selection.
- [40] $\ominus \rightarrow$ **G Y**
G or Y signal output according to selection.
- [41] $\ominus \rightarrow$ **B P_b**
B or P_b signal output according to selection.
- [42] Mains input and fuse carrier unit with voltage selector.
- [43] $\triangle!$ **S-VHS**
S-VHS connector.
- [44] **EURO-AV**
Scart connector
- [45] **RS-232C**
RS-232C port connector for remote control purposes.

4.2 Operating mode

4.2.1 Pattern selection

The pattern keyboard [7] allows selecting directly a pattern, the characteristics of which can vary according to format or system as listed in the specifications section. The selected pattern will appear in all the outputs except blackburst.

Each key allows the selection of one or more patterns. Besides each key there is a series of luminous indicators, one for each pattern which may be selected. The lit up indicator signals the active pattern. Keys allowing selection of more than one pattern have to be repeatedly pressed to sequentially select the various patterns. For example, to select the 5-step grey scale pattern (**5 STEP**) press the **10 STEP - 5 STEP** key twice, so long as you are not starting off from the 10-step pattern itself, in which case it will only be necessary to press once.

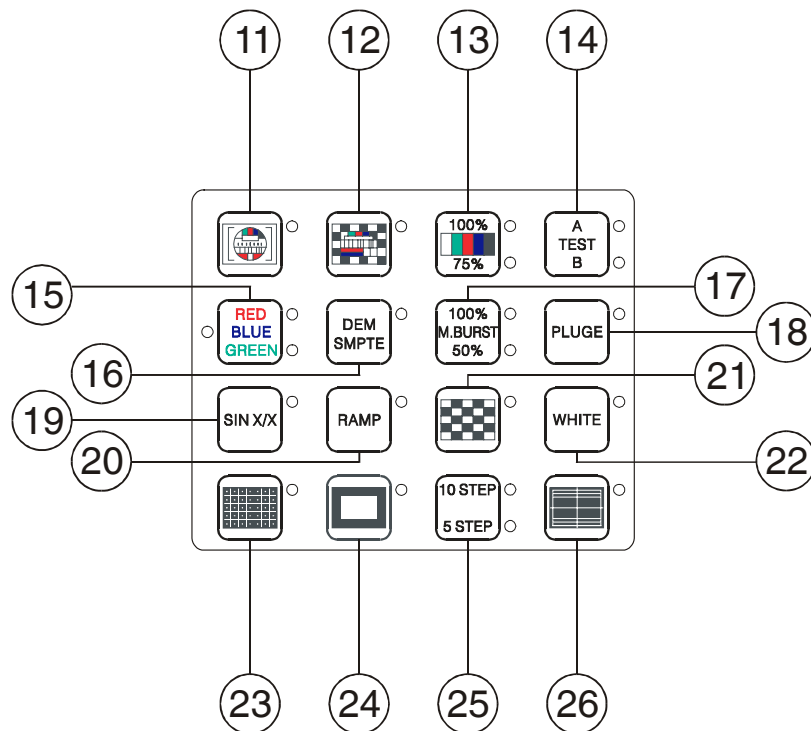

Figure 4.- Pattern selection keyboard

[11] Selection of pattern n° 1: Complete pattern, 4:3 format

[12] Selection of pattern n° 2: FuBK pattern

PAL system

- FuBK pattern

SECAM system

- Colour bars (100/0/75/0)

NTSC system

- SMPTE mixture. SMPTE1, SMPTE2 and SMPTE3 signals.

[13] Selection of pattern n° 3: Colour bars. Press the key repeatedly to cyclically choose between two different patterns:

PAL and SECAM systems

- 100/0/75/0 colour bars
- 75/0/75/0 colour bars

NTSC system

- SMPTE1 colour bars
- 75/0/75/0 colour bars

- [14] **Selection of pattern n° 4: VITS.** By pushing this chart key cyclically it is possible to select between two different charts:

B/G/L/D/K systems

- VITS line CCIR17
- VITS line CCIR330

I system

- VITS line ITS I
- VITS line ITS II

NTSC system

- VITS line FCC composite
- VITS line NTC-7 composite

- [15] **Selection of pattern n° 5: PURITY.** By pushing this chart key cyclically it is possible to select between three different charts:

- Complete picture of red signal.
- Complete picture of blue signal.
- Complete picture of green signal.

- [16] **Selection of pattern n° 6 : DEM**

PAL system

- 5 vertical bars. White level 50%.
Colour signals from left to right
R-Y (90°/90°), B-Y=0.
B-Y (0°/180°), R-Y=0.
B-Y (180°/0°), R-Y=0.
R-Y (270°/270°), B-Y=0.
R-Y=0, B-Y=0.

SECAM system

- Colour bars 100/0/75/0

NTSC system

- SMPTE3 signal

- [17] **Selection of pattern n° 7: Multi-burst.** By pushing this chart key cyclically it is possible to select between two different charts:

B/G/I/L/D/K systems

- White (100%) and black bars.
6 blocks of 0.5 / 1.0 / 2.0 / 4.0 / 4.8 / 5.8 MHz 100% of the white level.
Sinusoidal signals
- VITS line CCIR18

M, N systems

- White (100%) and black bars.
6 blocks of 0.5 / 1.0 / 2.0 / 3.0 / 3.58 / 4.2 MHz 100% of the white level.
Sinusoidal signals
- VITS line FCC MULTI-BURST

[18] **Selection of pattern n° 8: Pluge**

[19] **Selection of pattern n° 9: Sin X/X**

[20] **Selection of pattern n° 10: Ramp**

[21] **Selection of pattern n° 11: Checkerboard**

[22] **Selection of pattern n° 12: White**

[23] **Selection of pattern n° 13: Convergence**

[24] **Selection of pattern n° 14: Window**

[25] **Selection of pattern n° 15: Grey scale.** By pushing the chart key cyclically it is possible to select between two different charts:

- 10 levels white and black staircase
- 5 levels white and black staircase

[26] **Selection of pattern n° 16: Centring**

4.2.2 Systems configuration

The **GV-898+** TV pattern generator enables configuring a large variety of parameters. So that the most common configurations may be selected without having to individually modify parameters, the instrument will store up to 32 configurations (00 to 31) in its memory.

The different parameters which may be modified have been grouped into four configuration menus:

VIDEO-AUDIO
TXT-VPS
SYNC-LOGO-SCART

To view the parameters relative to each menu in the display and thus verify the configuration in use and/or modify it, simply press the selection key of the corresponding menu [3], [4] or [5].

Once the configuration menu you seek to consult or whose parameter you intend to change appears in the display, you can progressively select the different parameters by turning the rotary selector [6]. The selected parameter will appear shadowed.

To activate a parameter and thereby change its configuration, once selected (when it is shadowed), press the rotary selector, and the parameter will be underlined (activated), on turning the rotary selector [6] the various possible options for that parameter will appear. Pressing on the selector again re-establishes the selection mode. The changes produced in the display directly affect the information present at the generator output, though they do not alter the previously stored configurations, therefore the modified modifications will be lost on switching off the generator.

If you wish to store the new configuration, from any of the configuration menus, select the **STORE** field (appearing shadowed), press the rotary selector to activate it (appearing underlined), turn it to select the memory number according to the format **STOXX** (XX from 00 to 31), and finally press the rotary selector until you hear the signal (the current state of all the parameters on the three configuration menus will then be stored in the chosen memory).

The different parameters which may be modified in each of the configuration menus is described next.

4.2.2.1 ANALOG configuration menu

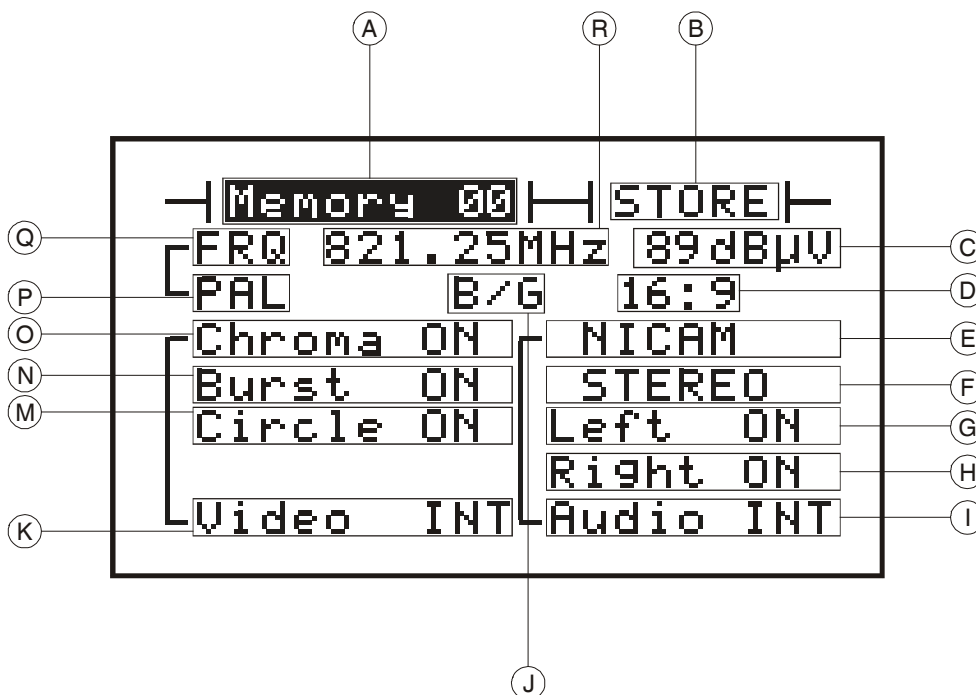

Figure 5.- Example of the VIDEO-SOUND configuration menu display

- [A] **Memory**
Shows the active memory position. At start up the initial position is 00. To activate a different memory, select this field (seen shadowed in figure 5) and activate it by pressing the rotary selector. Then, by turning it, it will be possible to load one of the stored memories (from position **00** to **31**). This field appears in all the configuration menus.
- [B] **STORE**
Allows storing the parameters active in the three configuration screens onto a memory position. To do this, after selecting the **STORE** field (appearing shadowed), press the rotary selector to activate it (appears underlined), turn to select the memory number according to the **STOXX** format (XX from 00 to 31), and finally press the rotary selector again until you hear the confirmation signal (the current state of all the parameters of the three configuration menus will then be stored in the chosen memory). This field appears in all the configuration menus.
- [C] **SIGNAL LEVEL**
Signal level at the RF output in dBV, variable in jumps of 1 dB. Maximum attenuation 60 dB.
- [D] **FORMAT**
Format selection between **4:3** or **16:9**.
- [J] **TELEVISION SYSTEM**
Television system selection between **B/G**, **I**, **D/K**, **L**, **M** or **N**
- [P] **COLOUR SYSTEM**
Colour system selection between **PAL**, **SECAM** or **NTSC**.
- [Q] **TUNING MODE**
Tuning mode selection between *tuning by frequency* **FRQ**, or *tuning by channel*, in the latter case the name of the channel table appears in the display: **CCIR**, **STD L**, **OIRT** or **FCC** (on the basis of the stored channels, see appendix A).
- [R] **TUNING**
RF output frequency selection. In the frequency tuning mode this parameter can vary between 37 MHz and 865 MHz in progressive jumps of 50 kHz. The name of the channel appears if in the channel tuning mode.

PARAMETERS REGARDING SOUND MODULATION:

- [E] **SOUND SYSTEM**
Selection of sound system between **MONO**, **ZWEITON**, **NICAM** and **Sound OFF** (without carrier).
- [F] **2nd SOUND CARRIER**
Selection of sound between **STEREO** and **DUAL**
- [G] **LEFT SOUND CHANNEL MODULATION**
Activation, **Left ON**, or deactivation, **Left OFF**, of the left sound channel.

- [H] **RIGHT SOUND CHANNEL MODULATION**
Activation **Right ON** or deactivation **Right OFF**, of the right sound channel.
- [I] **SOUND MODULATION**
Selection of the audio modulation signal between **Audio-INT** (interior), **Audio-EXT** (exterior).

PARAMETERS REGARDING VIDEO MODULATION:

- [K] **VIDEO MODULATION**
Selection of the video modulation signal between **Video-INT** (interior), **Video-EXT** (exterior).
- [M] **CIRCLE**
Activation of the circle **Circle-ON**, or deactivation **Circle-OFF**.
- [N] **BURST**
Activation, **Burst-ON**, or deactivation, **Burst-OFF**, of the burst signal.
- [O] **CHROMINANCE**
Activation, **Chroma-ON**, or deactivation, **Chroma-OFF**, of the chrominance signal.

4.2.2.2 TXT-VPS configuration menu

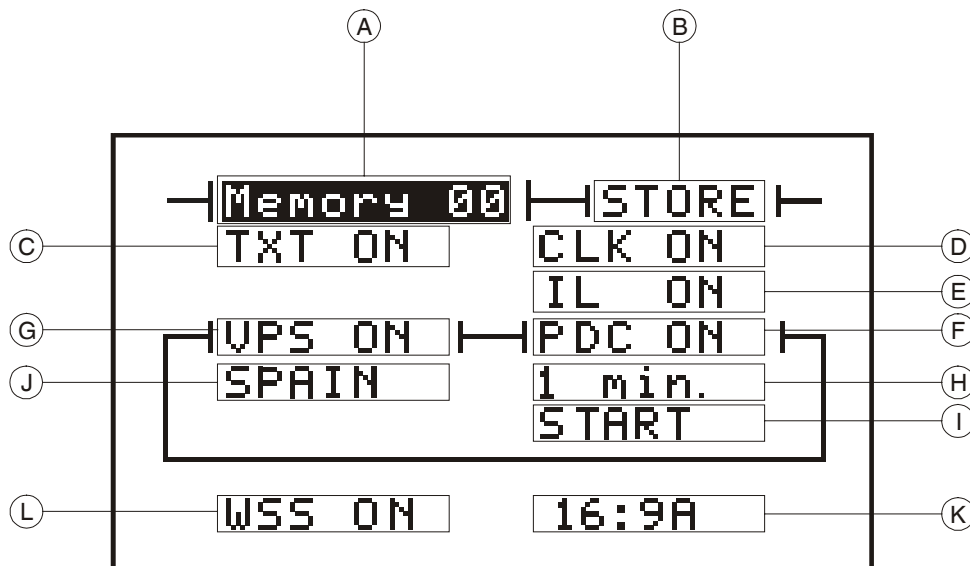

Figure 6.- Example of the TXT-VPS configuration menu display

The **Memory** and **STORE** fields operate as described in the VIDEO-SOUND configuration menu.

- [C] **TELETEXT**
Activation, **TXT ON**, or deactivation, **TXT OFF**, of the teletext signal. The frame identification is lost on activating the teletext in the SECAM system, this is not activated in the NTSC system.

[D] CLOCK

When the **CLK ON** field is activated, the image of a clock is seen in the bottom showing the hour, minute and second. This disappears when **CLK OFF** is deactivated.

In order to set the hour you must select the **CLK** field and later to press the rotary selector [6] until generator emits an acoustic signal, automatically the clock setting will be shown according to the format: **HH:MM:SS**. At this situation, turning the rotary selector [6], it is possible to modify both digits corresponding to hours; in order to modify the minute's field and the one of seconds, the rotary selector must be pressed [6]. After updating all fields and to activate the final clock updating you must press the rotary selector [6] afresh until hearing an acoustic confirmation signal.

[E] INTERLACING

Activation, **IL ON**, or deactivation, **IL OFF**, of the interlacing.

PARAMETERS REGARDING PDC AND VPS SIGNALS

VPS (Video Program Service) and PDC (Program Delivery Control) are information signals, which are emitted by television channels during a program, that may activate or stop the users' video recorders if they are equipped with this feature.

[F] PDC SIGNAL, PROGRAMME DELIVERY CONTROL

Activation, **PDC ON**, or deactivation, **PDC OFF**, of the *Programme Delivery Control* signal.

[G] VPS SIGNAL, VIDEO PROGRAMME SYSTEM

Activation, **VPS ON**, or deactivation, **VPS OFF**, of the *VPS* signal.

[H] TIMING

Selection of minutes between **1 min.** or **5 min.** Information on month (1), day (1) and time (1) is fixed.

[I] TRANSMIT SIGNAL

Selection of the transmit signal between **START**, **STOP** or **PAUSE**.

[J] COUNTRY

Selection of the country between **SPAIN**, **ENGLAND**, **FRANCE** or **GERMANY**.

[K] FORMAT

This field allows selecting the different formats the WSS.

[L] WIDE SCREEN SIGNALLING

Activation, **WSS ON**, or deactivation, **WSS OFF**, of Wide Screen Signalling. This signal acts on 16:9 format equipment which has a circuit detector for this signal.

4.2.2.3 SYNC-LOGO-SCART configuration menu

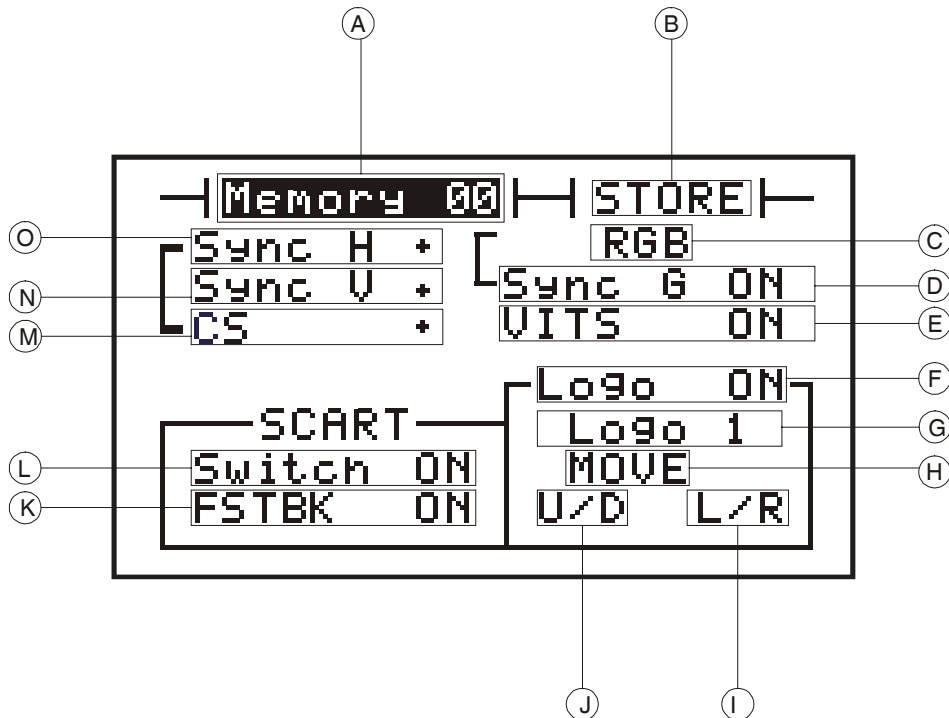

Figure 7.- Example of the SYNC-LOGO-SCART configuration menu display

The **Memory** and **STORE** fields operate as described in the VIDEO-SOUND configuration menu.

- [C] **RGB, Y P_b P_r**
Activation of outputs RGB or Y P_b P_r
- [D] **SYNCHRONISM SIGNAL IN GREEN**
Activation, **Sync G ON**, or deactivation, **Sync OFF**, of the synchronism signal in the green signal.
- [E] **ACTIVATION OF THE TEST SIGNALS**
Activation, **VITS ON**, or deactivation, **VITS OFF**, of VITS signal insertion (*Video Insertion Test Signals*)

PARAMETERS REGARDING LOGOS

- [F] **LOGO ACTIVATION**
Activation, **Logo ON**, or deactivation, **Logo OFF**, of logos.
- [G] **SELECTION OF LOGO TO BE MOVED**
Logo 1 or **Logo 2**.
- [H] **LOGO POSITION**
Allows the logos to be moved, **MOVE**.

[I] **MOVEMENT RIGHT/LEFT**

When this field is activated the logo can be horizontally moved by tuning the rotary selector [6].

[J] **MOVEMENT UP/DOWN**

When this field is activated the selected logo can be vertically moved by tuning the rotary selector [6].

N.B.: The logos cannot be superimposed. The vertical position of logo 2 can never be more than 128 lines from the beginning of logo 1.

SCART CONNECTOR CONTROL PARAMETERS

[K] **FSTBK**

Activation, **FSTBK On** or deactivation, **FSTBK Off**, of the FSTBK signal. This signal activates/deactivates the R, G and B inputs of the television set.

[L] **SWITCH**

Activation, **Switch On**, or deactivation, **Switch Off**, of the SWITCH signal. This signal activates the external video/audio signals present in the scart connector according to the following table.

GV-898+ SWITCH SIGNAL	RECEIVER SWITCH SIGNAL	RESULT
ON	ON	Without communication (it depends on receiver type)
OFF	ON	GV-898+ scart connector inputs are active (VIDEO EXT [34] and SOUND EXT [30] and [31] activated)
ON	OFF	Receiver scart connector inputs are active
OFF	OFF	Without communication

Table 1.- Scart connector signals state according to SWITCH signal.

SETTING PARAMETERS FOR COMPOSITE SYNCHRONISM AND FOR THE HORIZONTAL¹ AND VERTICAL² PULSES

[M] **COMPOSITE SYNCHRONISM**

Selection of positive composite synchronism (**CS +**) or negative (**CS -**).

[N] **HORIZONTAL SYNCHRONISM**

Selects the positive horizontal synchronism (**Sync H +**) or the negative one (**Sync H -**).

[O] **VERTICAL SYNCHRONISM**

Selects the positive vertical synchronism (**Sync V +**) or the negative one (**Sync V -**).

¹ HORIZONTAL PULSE: The rise edge for the horizontal pulse appears 0.8 μ s before the beginning of the horizontal synchronism and the duration of the horizontal pulse is 7.2 μ s.

² VERTICAL PULSE: Is triggered with the vertical synchronism pulse, has 10 line periods of duration in systems of 625 lines and 6 line periods in systems of 525 lines.

5 DESCRIPTION OF INPUTS AND OUTPUTS

5.1 Composite video output (BNC)

The composite video output is achieved through the **VIDEO** connector $\ominus \rightarrow$ [9] on the front panel. The polarity of the signal is positive, the black level being 0 V. The output level is fixed to 1 Vpp. This signal is very useful in testing B/W and colour video monitors, linear amplifiers, VCR or any other equipment which operates with a composite video signal.



This signal must not be connected to any live point in a circuit, but only to normalized video inputs of 75 Ω impedance. Any damage produced in the equipment due to non-observation of this precaution is not covered by the guarantee.

5.2 Modulated RF output

The modulated RF output is achieved through the **RF** connector $\ominus \rightarrow$ [8] on the front panel.

The possibility of attenuating the RF output has been foreseen for testing the automatic gain control circuits and the sensitivity of television sets: permitting a total maximum attenuation of 60 dB in steps of 1 dB.

5.3 Audio inputs and outputs

The BNC connectors **R** [30] and **L** [31] permit the entry of external audio signals (right and left channel respectively) which can be used to modulate the TV signal audio carriers. Besides, the **R** [32] and **L** [33] connectors provide a low frequency output for the right and left channels respectively.

5.4 Video input and Blackburst output

The external video entry can be achieved through the **VIDEO** [34] BNC connector, on the rear panel.

The **BLACKBURST** [35] output provides a **Blackburst** signal which comprises a black image with complete frame and line synchronism and Burst and Chrominance signals. It acts as a standard synchronism generator for the synchronisation of all the equipment forming part of a production chain.

5.5 Synchronism output, vertical pulse and horizontal pulse

The **GV-898+** has three synchronisms outputs situated on the rear panel: **CS** [36] composite synchronism output (horizontal and vertical), **V** [37] vertical synchronism output, and **H** [38] horizontal synchronism output. Synchronism polarity may be selected from the SYNC-LOGO-SCART configuration menu.

5.6 R-G-B/ Y P_b P_r output

The **R-G-B/Y P_b P_r** outputs are situated on the rear panel, through three BNC sockets **R P_r** [39], **G Y** [40] and **B P_b** [41], respectively.

By means of the SYNC-LOGO-SCART configuration menu, it is possible to insert synchronisms in the G/Y output and selectioner RGB or YP_bP_r output.

5.7 S-VHS output (ANALOG). S-VHS input (MPEG2)

This is via the 4-contact socket **S VHS** [43] on the rear panel.

Separate luminance and chrominance outputs used in the S-VHS system are available. Their use as a high quality video standard is becoming more and more widespread and the quantity of television sets and video equipment incorporating them is increasing. It is used as input to convert a S-VHS signal to MPEG2.

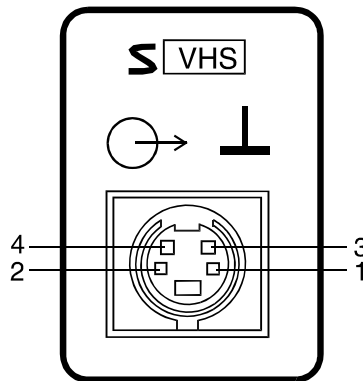

Figure 8.- S-VHS socket

- [1] Luminance signal ground
- [2] Chrominance signal ground
- [3] Luminance signal
- [4] Chrominance signal

5.8 SCART connector (DIN EN 50049)

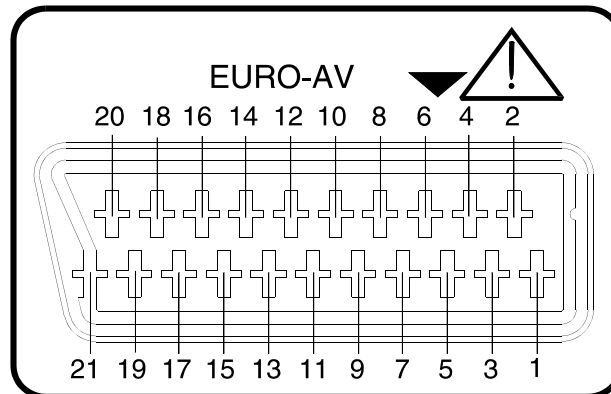

Figure 9.- Scart socket

Also known as EUROCONNECTOR or PERITEL connector (according to the NF-C92250 norm). The output signals in this socket as follows:

PIN Nº	SIGNAL	CHARACTERISTICS
1	Audio right channel output	
2	Audio right channel input	
3	Audio left channel output	
4	Audio ground	
5	Blue ground (B)	
6	Audio left channel input	
7	Blue output (B)	
8	Switching voltage (<i>switch</i>)	0 to 2 V for 0 logic 4.5 to 7 V for 1 logic, 4:3 format 10 to 12 V for 1 logic, 16:9 format
9	Green ground (G)	
10	Digital bus interface	(not connected)
11	Green output (G)	
12	Interface digital bus	(not connected)
15	Red ground (R)	
16	Blanking signal	(not connected)
15	Red ground (R)	
16	Blanking signal	0 to 0.4 V for 0 logic 1 V for 1 logic
17	Composite video ground	
18	Blanking ground	
19	Composite video output	
20	Video input	
21	Connector shell ground	

6 MAINTENANCE

6.1 Replacing the mains fuse

The fuseholder lid is placed in the mains base (see figure 1).

To substitute the fuse, disconnect the power cord.

With an appropriate screw driver remove the fuseholder lid.

Substitute the melt fuse for another of the following characteristics:

IMPORTANT

FUSE TYPE SHOULD BE: 5 x 20 mm., and:

0.5 A	T 250 V	FOR	220, 230/240 V
1 A	T 250 V	FOR	110 and 125 V

AVOIDING THIS DIRECTIONS COULD DAMAGE THE EQUIPMENT.

When inserting the fuseholder lid be careful that the voltage selector is in the correct position according to the mains.

6.2 Cleaning recommendations

CAUTION

TO CLEAN THE COVER, TAKE CARE THE INSTRUMENT IS DISCONNECTED.

CAUTION

DO NOT USE SCENTED HYDROCARBONS OR CHLORIZED SOLVENTS. SUCH PRODUCTS MAY ATTACK THE PLASTICS USED IN THE CONSTRUCTION OF THE COVER.

The cover should be cleaned by means of a light solution of detergent and water applied with a soft cloth.

Dry thoroughly before using the system again.

7 REMOTE CONTROL COMMANDS

The **GV-898+** has incorporated the same type of remote control that was designed for the **PROLINK-1** and **7**. The transference procedure is based on protocols **XON-XOFF** and **ACK-NAK**, through a **RS-232C** port series working at **19200 bauds, 8 bits, none parity** and **1 stop bit**.

On this structure, executive and interrogatory commands, are transmitted to allow of changing the equipment configuration or operation or, to interrogate about its state.

The commands are the base to implement the remote control of the equipment, that allows so much the automatization of some processes, like the generation of control application by the end user.

The equipment dispatches the received commands through the port series on automatic mode, with no need any special type of action from the frontal panel. The commands available are extended in each version, according to their necessity.

Some of the commands shall have introduced previously a password to operate, since are destined to the instrument control during the manufacturing process or the post-sale service. Others are generic and oriented to user applications.

At this moment, for **firmware 2.12 version**, the available commands are those indicated in the following table:

Remote Mode Commands			
Cmnd	Passwd	Format	Description
VE		*?VE<cr>	It returns the application version
NA		*?NA<cr>	It returns the equipment name
BE		* BE<cr>	It sounds an indicative tone of warning
CK		* CKhh:mm:ss<cr> *?CK<cr>	Sets the time of the internal clock Returns the internal clock time hh: hour from 00 to 23 mm: minutes from 00 to 59 ss: seconds from 00 to 59
WT		* WTnbfABC... Z<cr>	It creates a text window n "ABC... Z" n: window number (0,1,2) b: RGB background colour (4 bits: 0rgb) f: RGB text colour (4 bits: 0rgb)
WM		* WMn0<cr> * WMn1bf<cr>	It eliminates window n (OFF) It sets new colours window n n: window number (0,1,2) b: RGB background colour (4 bits: 0rgb) f: RGB text colour (4 bits: 0rgb)

Remote Mode Commands			
Cmnd	Passwd	Format	Description
FR		* FRnnnn<cr> *?FR<cr>	Sets a new PLL value Reads present PLL value
AT		* ATnn<cr> *?AT<cr>	It sets a new attenuation value Read the present attenuation value n: value of atten. in dB (hex) ---> 00: 0 dB 3C: 60 Db
PA		* PAnn<cr> *?PA<cr>	It sets active pattern Reads present pattern n: active pattern code ---> 00: COMPLETE 01: FUBK 02: BARS100 03: BARS75 04: CCIR17 05: CCIR330 06: RED 07: GREEN 08: BLUE 09: DEM 0A: MBURST100 0B: MBURST50 0C: PLUNGE 0D: SINX 0E: RAMP 0F: DAMER 10: WHITE 11: CONV 12: WINDOW 13: STEPS10 14: STEPS5 15: CENTER
CF		* CFnn<cr> *?CF<cr>	Sets the frequency or channel mode Reads present C/F mode nn = 0: frequency mode nn > 0: channel set (nn-1) 01: CCIR 02: STD L 03: OIRT 04: FCC
RC		* RCnn<cr>	Recovers the configuration memory content "nn" nn: memory number in hex (between 00 and 1F)
ST		* STnn<cr>	Saves the present configuration to the equipment memory position "nn". nn: memory number in hex (between 00 and 1F)

Observations: related to the previous commands, it is necessary to consider the following observations:

- **All.pro** file contains samples of most of valid commands. The measurement, once executed with the PKTERM, from the corresponding **All.log** file, will allow to understand the answer format of the interrogatory commands.
- Since the remote control works like one more operating routine of the equipment, a high speed control cannot be considered. Depending on the complexity of the requested function, the command answer will take more or less time in taking place.
- On command **CK**, it is necessary to consider that in a new equipment, the clock does not start up until the hour has been programmed once. This can be carried out programming the hour through the port series or the keyboard.
- Command **WT** allows to create 3 lines of text located in the bottom part of the OSD screen, over the clock indication. Each line contains 24 characters.
- In command **FR**, the PLL calculation is common to both types of modulators and it is carried out multiplying the frequency value in MHz by 20 and converting the result to hexadecimal. If the equipment is in channel mode, will be positioned in the channel next to the indicated frequency value (e.g.: 471.25 MHz * 20 = 9425 = 0x24D1 = PLL ---> * FR24D1<cr>)

APÉNDICE A: Tablas de canal-frecuencia
APPENDIX A: Channel-frequency tables
ANNEXE A: Tables canal-fréquence

	Ch.	Freq.	Ch.	Freq.	Ch.	Freq.	Ch.	Freq.	Ch.	Freq.	Ch.	Freq.
CCIR	E02	48,25	E09	203,25	S24	327,25	S41	463,25	37	599,25	54	735,25
	E03	55,25	E10	219,25	S25	335,25	21	471,25	38	607,25	55	743,25
	E04	62,25	E11	217,25	S26	343,25	22	479,25	39	615,25	56	751,25
	S01	105,25	E12	224,25	S27	351,25	23	487,25	40	623,25	57	759,25
	S02	112,25	S11	231,25	S28	359,25	24	495,25	41	631,25	58	767,25
	S03	119,25	S12	238,25	S29	367,25	25	503,25	42	639,25	59	775,25
	S04	126,25	S13	245,25	S30	375,25	26	511,25	43	647,25	60	783,25
	S05	133,25	S14	252,25	S31	383,25	27	519,25	44	655,25	61	791,25
	S06	140,25	S15	259,25	S32	391,25	28	527,25	45	663,25	62	799,25
	S07	147,25	S16	266,25	S33	399,25	29	535,25	46	671,25	63	807,25
	S08	154,25	S17	273,25	S34	407,25	30	543,25	47	679,25	64	815,25
	S09	161,25	S18	280,25	S35	415,25	31	551,25	48	687,25	65	823,25
	S10	168,25	S19	287,25	S36	423,25	32	559,25	49	695,25	66	831,25
	E05	175,25	S20	294,25	S37	431,25	33	567,25	50	703,25	67	839,25
	E06	182,25	S21	303,25	S38	439,25	34	575,25	51	711,25	68	847,25
	E07	189,25	S22	311,25	S39	447,25	35	583,25	52	719,25	69	855,25
E08	196,25	S23	319,25	S40	455,25	36	591,25	53	727,25			
STDL	FA	47,75	13	240	23	487,25	35	583,25	47	679,25	59	775,25
	FB	55,75	14	288	24	495,25	36	591,25	48	687,25	60	783,25
	FC1	60,5	D01	303,25	25	503,25	37	599,25	49	695,25	61	791,25
	FC	63,75	D02	315,25	26	511,25	38	607,25	50	703,25	62	799,25
	05	176	D03	327,25	27	519,25	39	615,25	51	711,25	63	807,25
	06	184	D04	339,25	28	527,25	40	623,25	52	719,25	64	815,25
	07	192	D05	351,25	29	535,25	41	631,25	53	727,25	65	823,25
	08	200	D06	363,25	30	543,25	42	639,25	54	735,25	66	831,25
	09	208	D08	387,25	31	551,25	43	647,25	55	743,25	67	839,25
	10	216	D09	399,25	32	559,25	44	655,25	56	751,25	68	847,25
	11	224	21	471,25	33	567,25	45	663,25	57	759,25	69	855,25
	12	232	22	479,25	34	575,25	46	671,25	58	767,25		
OIRT	I	49,75	XII	223,25	31	551	42	639,25	53	727,25	64	815,25
	II	59,25	21	471,25	32	559,25	43	647,25	54	735,25	65	823,25
	III	77,25	22	479,25	33	567,25	44	655,25	55	743,25	66	831,25
	IV	85,25	23	487,25	34	575,25	45	663,25	56	751,25	67	839,25
	V	93,25	24	495,25	35	583,25	46	671,25	57	759,25	68	847,25
	VI	175,25	25	503,25	36	591,25	47	679,25	58	767,25	69	855,25
	VII	183,25	26	511,25	37	599,25	48	687,25	59	775,25		
	VIII	191,25	27	519,25	38	607,25	49	695,25	60	783,25		
	IX	199,25	28	527,25	39	615,25	50	703,25	61	791,25		
	X	207,25	29	535,25	40	623,25	51	711,25	62	799,25		
	XI	215,25	30	543,25	41	631,25	52	719,25	63	807,25		

FCC

A02	55,25	15	477,25	28	555,25	41	633,25	54	711,25	67	789,25
A03	61,25	16	483,25	29	561,25	42	639,25	55	717,25	68	795,25
A04	67,25	17	489,25	30	567,25	43	645,25	56	723,25	69	801,25
A05	77,25	18	495,25	31	573,25	44	651,25	57	729,25	70	807,25
A06	83,25	19	501,25	32	579,25	45	657,25	58	735,25	71	813,25
A07	175,25	20	507,25	33	585,25	46	663,25	59	741,25	72	819,25
A08	181,25	21	513,25	34	591,25	47	669,25	60	747,25	73	825,25
A09	187,25	22	519,25	35	597,25	48	675,25	61	753,25	74	831,25
A10	193,25	23	525,25	36	603,25	49	681,25	62	759,25	75	837,25
A11	199,25	24	531,25	37	609,25	50	687,25	63	765,25	76	843,25
A12	205,25	25	537,25	38	615,25	51	693,25	64	771,25	77	849,25
A13	211,25	26	543,25	39	621,25	52	699,25	65	777,25	78	855,25
14	471,25	27	549,25	40	627,25	53	705,25	66	783,25		