



T A B L E O F C O N T E N T S

1	GENERAL	1
1.1	Description	1
1.2	Specifications	2
2	SAFETY RULES	5
3	INSTALLATION	7
3.1	Power supply	7
3.1.1	Recharging the battery	7
3.2	Installing the battery	8
3.3	Installation and start-up	9
4	OPERATING INSTRUCTIONS	11
4.1	Description of the controls and elements	11
4.2	Operation instructions	13
4.2.1	Tuning mode selection	13
4.2.2	Carrier level measurement	15
4.2.3	Selection of the attenuators	17
4.2.4	Program storage	18
4.2.5	Sound selection	19
4.2.5.1	The F1 function	19
4.2.5.2	The F2 function	20
4.2.6	Measurement of the V/A ratio	21
4.2.7	Measurement of the C/N ratio	22
4.3	Connection to the computer	24
5	MAINTENANCE	25
5.1	Instructions for returning by mail	25
5.2	Method of maintenance	25
5.2.1	Cleaning the cover	25
5.2.2	Battery replacement	25
5.2.3	Battery charger fuse	25
	APPENDIXES	27
	APPENDIX A.- MEASUREMENT OF THE VIDEO CARRIER LEVEL (C _L)	27
	APPENDIX B.- MEASUREMENT OF THE ADJACENT CHANNEL LEVEL	28
	APPENDIX C.- MEASUREMENT OF THE VIDEO / AUDIO RATIO	29
	APPENDIX D.- CARRIER TO NOISE RATIO (C/N)	30
	APPENDIX E.- CARRIER / NOISE RATIO MEASUREMENT (C/N)	31

CABLE TV ANALYSER

PROMAX-4

1 GENERAL

1.1 Description

The **PROMAX-4** is an **advanced model** signal level meter designed for the installation and maintenance of television signal reception and distribution systems. The frequency range covered makes it an excellent instrument in **FM radio, TV (MATV) and cable TV (CATV) applications**. It is particularly suitable in the latter case, since it integrates all of the basic functions for the analysis of the signal in an easy-to-use, accurate, sturdy instrument at a low cost.

The **PROMAX-4** is the result of intensive work in research and the experience of more than thirty years in the development of instrumentation for television. It enables the measurement of the signal level with a high degree of accuracy; it incorporates a series of functions for evaluating the picture quality; it includes the calculation of the video-to-audio (V/A) ratio and of the carrier-to-noise (C/N) ratio in the channel (patented method).

Its design, **based on a control system with an intelligent microprocessor**, provides the user with easy-to-use advanced features. The digital control system allows the user to make most of the necessary operations automatic in order to optimize the measurement process; for example, continuous frequency **synthesis**, correction of linearity and flatness errors, the proper selection of attenuators and automatic cut-off if the instrument remains inactive for a certain period of time. To enhance its features, it allows a plan of up to 239 channels and is equipped with up to **64 program memories**.

Its accuracy and reliability satisfy the requirements of the most demanding users.

The signal level measured is shown numerically on an LCD display in absolute values. It is also equipped with a **computer connection** which allows one to personalize the configuration of the instrument.

The instrument is powered by an external rechargeable battery and it is safe to use outdoors.

The implementation of all these functions in an instrument weighing only half a kilo, makes the **PROMAX-4** an incomparable work tool.

Every detail has been carefully studied to achieve the best possible balance between its features and its operability. The result is an easy-to-handle piece of equipment with advanced functions, which may be used even by non-specialized personnel.

1.2 Specifications

TUNING

Tuning range	From 45 to 862 MHz.
Tuning mode	By channels, frequency or program (maximum 64).
Channel plan	CCIR ^{(1) (2)} .
Frequency	62.5 kHz resolution.
Programs	Storage of frequencies and channels from the keyboard ^{(1) (2)} .
Number of programs	Maximum of 64 programs. Limitation on number of programs from 64 to 1 ^{(1) (2)} .
Indication	LCD alphanumeric display with back lighting.

LEVEL MEASUREMENT

Measurement range	From 20 to 120 dB μ V. (from -40 dBmV to 60 dBmV) ⁽³⁾ .
Read	Digital in dB μ V (or dBmV ^{(1) (2)}). 1 dB resolution
Attenuator	Automatic or manual
IF bandwidth	230 kHz \pm 50kHz
Input impedance	75 Ω
Audible indicator	Tone which varies with the signal level.
Accuracy	\pm 2 dB (from 0 to 40 °C) for negative video modulation ⁽⁵⁾ .

VIDEO / AUDIO

Measurement	Ratio of video to audio carrier levels.
Range	From 0 to 40 dB
Audio subcarrier frequency	
Standard	5.5 MHz ^{(1) (2)} .
Variable	4-9 MHz.
Accuracy	\pm 2 dB (from 0 to 40 °C) for FM audio carrier ⁽⁶⁾ .

CARRIER / NOISE

Measurement	Ratio of the carrier level to the noise level in the channel.
Max. dynamic range	50 dB (80 dB μ V reference input level) (see appendix E).
Accuracy	\pm 3 dB typical (see appendix E)

SOUND

Demodulation	AM / FM
Output	Internal speaker / external headphones.

POWER SUPPLY

NiCd battery	7.2 V – 0.80 Ah.
Low battery indication	Indication on the display
Battery life	1 hour and 45 minutes (30 % on / off).
Automatic cut-off	Cut-off after approximately 12 minutes of non-use.
Mains to charger adapter	230 V / 50-60 Hz / 12 W minimum (EUROPE and other countries).
Battery charger	By fast external adapter. 12-16 VDC / 12 W.
Equipment consumption	3 W.

ENVIRONMENTAL CONDITIONS

This equipment could be used on the following environmental conditions, in these conditions the specifications could also be applied:

Altitude	Up to 2000 metres.
Temperature range	From 5 °C to 40 °C.
Maximum relative humidity	80 % (up to 31 °C), decreasing lineally up to 50% at 40 °C.

Degree of protection provided by the enclosure: IP-23 (tested for safety according to IEC529 and IEC1010-1)

MECHANICAL FEATURES

Dimensions	70 W (90 on the display) x 218 H x 50 D mm.
Weight	580 g. (including battery).

- (1) *Under request carried out at the factory. (See option OPT-008-61)*
- (2) *May be configured by PC by means of the RM-004 program. (See optional accessories).*
- (3) *There may be certain frequencies where the symbol "<" appears at levels higher than 20 dB μ V (maximum 23 dB). This is due to the automatic correction of the frequential response.
The value measured remains correct, although the accuracy becomes ± 3 dB*
- (4) *Accuracy specified for attenuation (ATT) in automatic mode*
- (5) *For the positive video modulation (Stand. L) it can vary from 0 to -2 dB among white and black image.*
- (6) *For the AM audio carrier (Stand L), it can vary from 0 to -3 dB below the V/A value*

INCLUDED ACCESSORIES

AL-012	EUROPE and other countries 230 V / 50-60 Hz mains adapter (basic version only).
AL-022	USA and CANADA 120 V / 50-60 Hz mains adapter (only with the OPT-008-1).
AL-032	UK 230 V / 50-60 Hz mains adapter (only with the OPT-008-2).
AL-042	Australia 240 V/50-60 Hz mains adapter (only with the OPT-008-3)
AL-052	Japan 100 V / 50-60 Hz mains adapter (only with the OPT-008-4).
AA-012	Car cigarette lighter adapter cable.
DC-234	Carrier case.
DC-286	Carrier belt.
AD-057	F/h - F/h input adapter.
AD-058	F/m - F/h rapid adapter.
CC-030	F/m - F/m (1m) coaxial cable.
CB-410	Battery charger module.
CB-038	7.2 V, 0.80 Ah NiCd rechargeable battery.
0 MI0869	User's manual

OPTIONS

OPT-004-1	Substitute mains adapter by AL-022.
OPT-004-2	Substitute mains adapter by AL-032.
OPT-004-3	Substitute mains adapter by AL-042.
OPT-004-4	Substitute mains adapter by AL-052.
OPT-004-61	Change channel plan. (Carried out under request in the factory).













OPTIONAL ACCESSORIES

AD-055	F/h - BNC/h adapter.
AD-056	F/h - IEC/h adapter.
DC-284	Rubber holster
CB-038	7.2 V - 0.80 Ah NiCd rechargeable battery.
RM-004	Programming pack. Enables the change, by means of a PC, of the channel tables, measurement unit (dB μ V, dBmV), etc.

2 SAFETY RULES

- * Use this equipment connected **only to devices or systems with their common at ground potential**.
- * This equipment can be used in **Over-Voltage Category I** installations and **Pollution Degree 2** environments.
- * When using some of the following accessories **use only the specified ones** to ensure safety.
 - Power adapter
 - Rechargeable battery
 - Car cigarette lighter adapter
 - Battery charger
- * Observe all specified ratings both of supply and measurement.
- * Use this instrument under the specified environmental conditions.
- * The user is only authorised to carry out the following maintenance operations:
 - Battery replacementOn the Maintenance paragraph the proper instructions are given.
Any other change on the equipment should be carried out by qualified personnel.
- * Follow the cleaning instructions described in the Maintenance paragraph.

* Symbols related with safety:

	DIRECT CURRENT
	ALTERNATING CURRENT
	DIRECT AND ALTERNATING
	GROUND TERMINAL
	PROTECTIVE CONDUCTOR
	FRAME TERMINAL
	EQUIPOTENTIALITY
	ON (Supply)
	OFF (Supply)
	DOUBLE INSULATION (Class II protection)
	CAUTION (Risk of electric shock)
	CAUTION REFER TO MANUAL
	FUSE

3 INSTALLATION

3.1 Power supply

The **PROMAX-4** is an portable instrument powered by a built-in 7.2 V NiCd rechargeable battery. Before taking any measurement, the user should make sure that the battery is fully charged (use the charge/discharge charger supplied with the instrument).

3.1.1 Recharging the battery

The battery charger has an automatic protection circuit to prevent any possible damage of the unit due to defective batteries.

The instrument is equipped with a 230 V / 50-60 Hz mains adaptor for Europe and other countries to power the battery charger. (See accessories to place an order for other types of adapters).

1. Connect the cable from the mains adapter to the charger. Connect the adapter to the mains. Insert the battery in the charger **once** the adapter-charger is **connected to the mains**.
2. **Discharge the battery prior to carrying out the charging process** in order to eliminate any possible residual charge. In order to do so, press button A situated on the right (see figure 1). At this point, a small yellow light comes on and the process of discharging is under way. When discharging is completed, the charger automatically sets the process of charging underway.
3. The **charging process** lasts for two and a half hours. When the process is completed, the three red indicators will light up. At the same time, an indicator will flash and an acoustic alarm will sound for 90 seconds, indicating that the charging process has been successfully completed.
4. After this period, if the battery is not removed from the charger it will remain in permanent **minimum charge mode**. A green LED will flash until the battery is removed.

CAUTION

1. *Before using the charger, make sure that the adapter is suitable for the mains voltage. An indicator will light up when the adapter is connected to the mains and the charger is connected.*
2. *This charger is designed for charging Ni-Cd batteries.*
3. *In order to prolong the lifetime of the batteries, it is advisable not to remove it from the charger while the charging process is still under way.*
4. *The mains adapter and the battery charger are designed for indoor use.*
5. *When using the battery first time, it is advisable to carry out two charging and discharging processes into the charger itself, in order to eliminate any possible memory effect, accumulated during the period it has been in storage.*

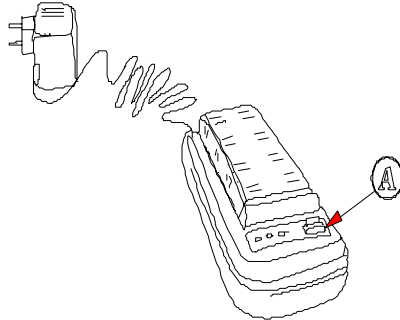



Figure 1.- CB-410 battery charger and mains adapter.

3.2 Installing the battery

Attaching the battery

 Use **CB-038** batteries only.

To attach the battery, position it on the base of the arrows found on the back of the instrument. Slide the battery until you hear a click and it remains fixed, as shown in the figure 2.

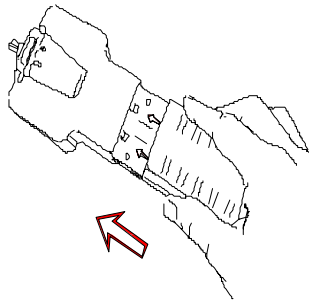

Figure 2.- Installing the battery.

Removing the battery.

The battery is accessible from the back of the instrument. To disconnect the battery, press the tab found at one end of it (1) and move the battery to separate it from the body of the instrument (2). The battery will be released from its holder. Then slide the battery out, as shown in figure 3.

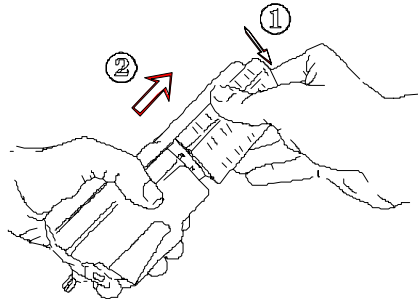

Figure 3.- Removing the battery.

3.3 Installation and start-up.

The **PROMAX-4** has been designed for use as portable equipment. When the battery is installed and the instrument is connected, the version of the instrument and the channel plan which it has stored will appear on the display for a few moments.

Ver. 1.36 CH:CCIR

When this indication appears, the instrument is in program tuning mode, PRO:00. By means of the program RM-004, one can select the starting up of the instrument in one of the three tuning modes: FREQ, CHAN or PROG.

When the ON/OFF key [12] is pressed, the instrument is then in "automatic cut-off" mode; in other words, the device is automatically disconnected when twelve minutes in operation have gone by without a key being pressed.

The automatic cut-off mode can be deactivated by holding down the ON/OFF key for one or two seconds when the device is connected. The indicator "manual power off" will appear on the display.

MANUAL POWER OFF

If the battery is low (at a voltage of less than 6.5 V), a blinking LOW BATTERY message will appear on the display [3]. When the voltage is lower than 6.0 V, the instrument disconnects.

A fully charged battery can power the equipment non-stop for more than an hour and a half. At 30% stop/start of intermittent operation, the battery can power it for up to five hours. When the LOW BATTERY indicator appears, the battery must be recharged.

When a fully discharged battery is installed, it is possible that, due to residual charges, the **PROMAX-4** may start up. In this case, the instrument will automatically disconnect before the message LOW BATTERY appears on the display.

4 OPERATING INSTRUCTIONS

4.1 Description of the controls and elements

Front panel

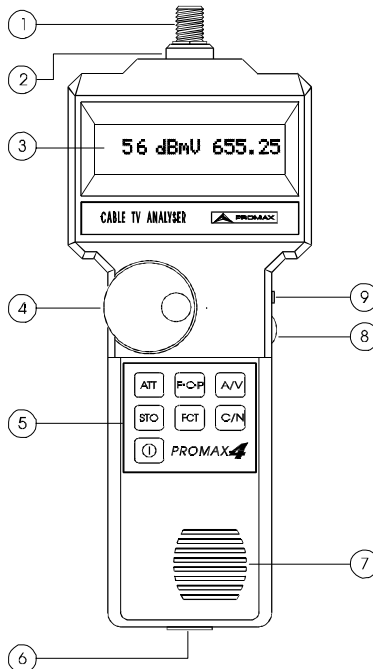

Figure 4.- Front view.

- [1] F-F (or F-BNC or F-IEC) adaptor



Maximum input voltage level 60 VAC rms /50-60 Hz

- [2] "F" male base connector
- [3] Alphanumeric display with back lighting. Indicates the level, the frequency/channel/program, the sound system, the attenuator, and the measurements of the video/audio and carrier/noise ratios.
- [4] Rotary switch. Used for continuous tuning control or for selecting the various options associated with each key.
- [5] Keyboard. Seven keys for selecting the functions

- [6] Connection to computer (for option RM-004)

OCA2170 specific connection cable supplied with option RM-004



Do not connect any cable other than that supplied by the manufacturer with option RM-004, otherwise the instrument may suffer serious damage.

- [7] Speaker
- [8] Volume control
- [9] External headphones connector

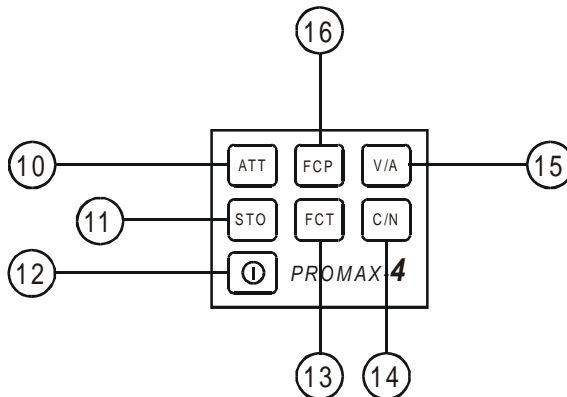

Figure 5.- Keyboard of the PROMAX-4

- [10] Manual or automatic attenuation switch. The input attenuation may be selected from 0 dB up to 70 dB in 10-dB steps. In the AUTO mode, the instrument selects the best attenuation as a function of the signal level in the input of the instrument, in order to centre the value of the reading in the optimal scale.
- [11] Program storage (maximum of 64). Press this key to store the configuration in the memory.
- [12] ON/OFF. Connects/disconnects the instrument and allows the user to select automatic or manual cut-off.
- [13] Special functions
 F1: Sound AM / FM / LEVEL / OFF
 F2: Sound subcarrier tuning from 4 - 9 MHz
- [14] Measurement of the carrier-to-noise ratio. Press this key to measure the carrier-to-noise ratio of the signal, once the video carrier level is stabilized.

- [15] Measurement of the video-to-audio ratio. Press this key to measure the video-to-audio ratio of the signal, once the video carrier level is stabilized.
- [16] Tuning mode: frequency, channel, program. Press this key to select among tuning by frequency, channel or program.

4.2 Operation instructions

4.2.1 Tuning mode selection

The **PROMAX-4** has three different tuning modes:

- By frequencies: From 45 to 862 MHz in steps of 62.5 kHz, using the rotary switch. The values displayed are given in MHz, with a two-decimal resolution.
- By channels: The channel plan in the CCIR standard or may be established under request (OPT-004-61), or be configured by the user (RM-004), with a maximum of 239 channels.
- By programs: The program plan may be configured either from the instrument itself or by using the customized configuration software (RM-004), with a maximum of 64 programs.

To select one of the three tuning modes, press the F-C-P key [16]. Turn the rotary switch to select among the program, channel or frequency modes. When the desired tuning mode is displayed, press the F-C-P key [16] again.

Example 1: Changing from channel mode to frequency mode.

This procedure can be useful in discovering the real frequency in MHz of the selected channel. The example illustrates finding the frequency which corresponds to channel 44.

74 dB μ V C44



74 dB μ V 655.25

Example 2: To change the frequency value from 62.25 MHz up to 850 MHz.

Due to the high resolution of the instrument (62.5 kHz) it is not very efficient to move through all the bands in frequency mode. A satisfactory solution is to use the channel mode to make substantial changes in frequency, as is shown in the example below.

74 dB μ V 62.25

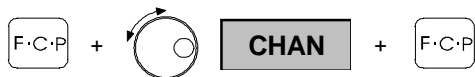

74 dB μ V C04

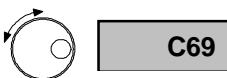

The selection of the channel situated in a frequency close to the desired frequency.

<7 dB μ V C69



<7 dB μ V 855.25

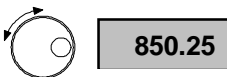

87 dB μ V 850.25

Note: When changing from frequency to channel, if the frequency tuned does not correspond to any channel, the **PROMAX-4** will search for the channel nearest to this frequency and will remain tuned to this channel. This operation may take several seconds.

Example 3. Tuning by program

Go to program 10 where the frequency 102.5 MHz is memorized

87 dB μ V 850.25



The number of the program used last appears, or 00 where this is not applicable.

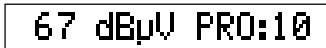

The diagram below shows the order of selection using the rotary switch of the F-C-P function.

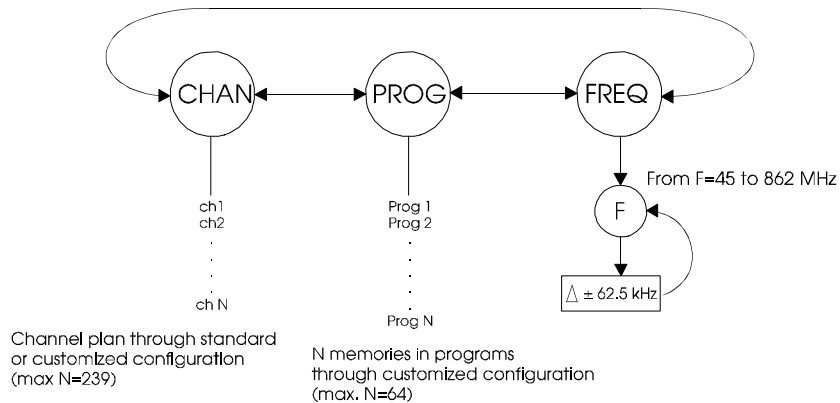

Figure 6.- F-C-P function

4.2.2 Carrier level measurement

- Select the desired tuning mode and tune the signal to be measured in the manner explained in Point 4.2.1.
- Wait until the measured value is stabilized. Read the value shown on the display. The units will be given in dBµV (dBmV using the option OPT-004-61, or by means of the customization program RM-004).
- The direct read range of the instrument is from 20 to 120 dBµV, and within this range the measurement is completely automatic. The microprocessor calculates the attenuation value corresponding to the proper measurement range. When the signal level being measured is lower/equal than the sensitivity or higher/equal than the saturation level of the instrument, the symbols "<" or ">" will appear, respectively.

- There may be certain frequencies where the symbol "<" appears at levels higher than 20 dB μ V (maximum 23 dB). This is due to the automatic correction of the frequential response. The value measured remains correct, although the accuracy becomes ± 3 dB.
- When the tuning is carried out by channels, it is possible that the broadcasting station deviates a few kHz with respect to the channel frequency. If this variation is higher than 40 kHz, tune again using this time the frequency mode, to obtain a more correct level reading.

Example 4. Measuring the video carrier level in channel 21 (CCIR standard).

74 dB μ V C24

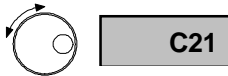

84 dB μ V C 21

Example 5. Measuring the commercial FM carrier (105.00 MHz)

84 dB μ V C 21

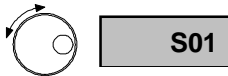

Channel S01 is nearest to the desired frequency.

22 dB μ V S 01



22 dB μ V 105.25

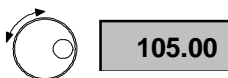

28 dB μ V 105.00

Example 6. Measuring a signal outside the measurement range. The sound subcarrier in channel 44 (655.25 MHz + 5.5 MHz = 660.75 MHz).



- El nivel de ruido del equipo se encuentra entre los 5 y 7 dBµV. Esto significa que el equipo puede medir señales entre 10 y 20 dBµV. El signo “<” aparece para indicar que en esta zona de medida puede que no se cumpla la precisión especificada, pero en la mayoría de los casos es una medida válida a todos los efectos.



4.2.3 Selection of the attenuators

AUTO attenuation

When the instrument is operated in a normal way must be switch to the AUTO position. This means that the instrument is calculating continuously the optimum attenuator value depending on the input signal. In order to verify that the attenuation is set to AUTO mode just push the ATT key and check the AUTO indication is appearing on the display. In the case it does not appear on the display then turn the knob until AUTO is displayed. Push again on ATT key and the instrument will be set to automatic attenuation mode.

Example 7. Checking whether the instrument is in AUTO mode.



Manual attenuation

In the measurement of certain signals in particular situations (the presence of high level carriers which create intermodulation products and saturation effects), it is necessary to set the attenuation value manually. To do this, press the ATT key [10]. By turning the rotary switch [4], the user can select the attenuation in the input from 0 to 70 dB.

The diagram below shows the order of selection using the rotary switch of the ATT function.

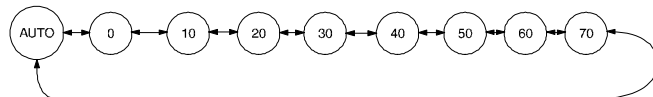

Figure 7.- ATT function

Following table displays the attenuator values which are used for every signal level. Should the selected attenuator value not be adequate for the signal level available a "<" or ">" symbol will appear on the display thus indicating that the attenuator value must be changed again.

Once all required measurements are performed, AUTO mode attenuation should be restored. Push ATT key, turn the knob until AUTO is selected and push ATT key again.

Signal level (dBmV)	Signal level (dB μ V)	Attenuator
-40 to -10	20 to 50	0 dB
-20 to 0	40 to 60	10 dB
-10 to 10	50 to 70	20 dB
0 to 20	60 to 80	30 dB
10 to 30	70 to 90	40 dB
20 to 40	80 to 100	50 dB
30 to 50	90 to 110	60 dB
40 to 60	100 to 120	70 dB

Example 8. Selecting a 10 dB fixed attenuator.

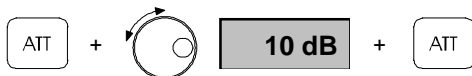

4.2.4 Program storage



This function enables the storage of a frequency, a channel or a program to a program setting chosen by the user (maximum of 64 programs). There are two methods for storing a pre-tuning configuration.

1. With a computer, using the computer connection of the instrument (RM-004)
2. With the STO key

Example 9. Storing channel C24 in program 05

74 dB μ V C24



74 dB μ V STO 00



STO 05

74 dB μ V STO 05



74 dB μ V C24

From this point on, in the program setting PRO:05 we shall have the frequency corresponding to channel 24 stored.

Note: *If a configuration is stored in a memory which contains information, the old values will be lost and replaced by the new ones. If any key is pressed other than STO, the memory will not function.*



4.2.5 Sound selection

The FCT key enables the user to access a menu with 2 configuration functions: F1 and F2.

4.2.5.1 The F1 function.

This function selects three kinds of sound demodulation together with the disconnection of the sound itself.

- FM: FM sound
- AM: AM sound
- LV: The speaker emits a tone whose frequency varies as a function of the signal level received.
- OFF: Sound not selected

The demodulation of both AM and FM is effected on the carrier tuned.

To select the type of sound, press the FCT key [13], select the F1 function and turn the rotary switch until the desired type of sound is displayed. Press the FCT key [13] again to activate the desired mode.

Example 10. Changing the sound from FM to LV

74 dBµV C44



74 dBµV FCT: F1



74 dBµV F1: FM



74 dBµV C44

The diagram below shows the order of selection using the rotary switch of the FCT (F1) function.



Figura 8.- Menú de la función F1

4.2.5.2 The F2 function

This function enables the user to vary the frequency of the sound subcarrier from 4 to 9 MHz, in 62.5 kHz steps.

This function is necessary if the user wants to vary the frequency of the sound subcarrier related to the measurement of the V/A ratio (see Point 4.2.6). The instrument takes as the default frequency the value configured in the factory (or a customized configuration through RM-004). However, with the F2 function the user can vary the sound subcarrier value manually, from 4 to 9 MHz.

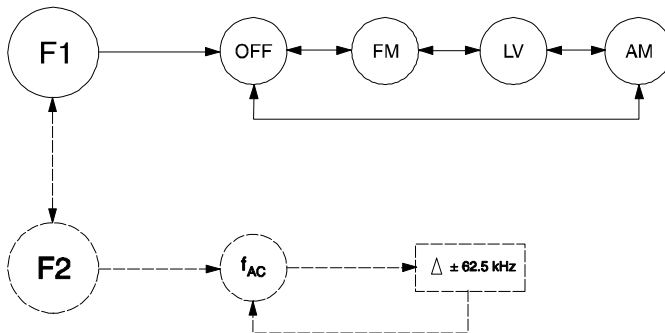
Example 11. Changing the sound subcarrier frequency from the standard value to 5.74 (Zweiton Stereo).

74 dB μ V C44

FCT

74 dB μ V FCT: F1



F2

74 dB μ V FCT: F2

FCT

74 dB μ V 5.5



5.75

74 dB μ V 5.75

FCT

74 dB μ V C44

The diagram below shows the order of selection using the rotary switch of the FCT (F2) function.

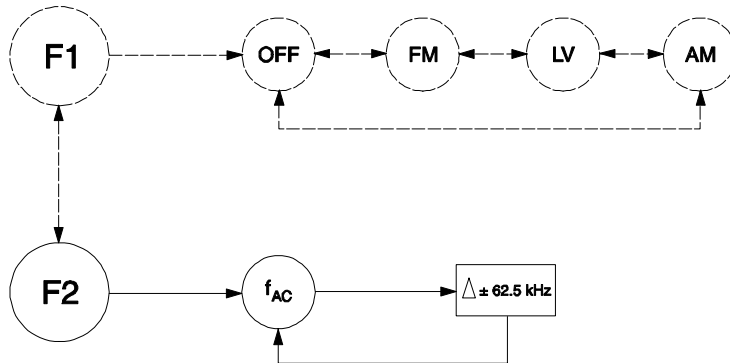

Figure 9.- Menu of the F2 function

Note: The new value chosen in functions F1 and F2 only remain in the memory until the battery is removed. When the battery is removed the instrument undergoes a RESET and the values configured through the F1 and F2 functions are lost. When the battery is reconnected, the instrument adopts the factory-configured values or those programmed by means of RM-004.

4.2.6 Measurement of the V/A ratio

V/A

This function allows the user to measure the ratio of the signal levels of the video carrier of a channel and the corresponding audio carrier of the same channel. In addition, there is an automatic demodulation of the sound in FM or AM, in accordance with the option selected, as explained in Point 4.2.5.1.

Follow the steps below to take this measurement:

1. Tune the desired video carrier and wait a few seconds until the read level is stabilized.
2. Press the V/A key
3. Wait until the measurement is stabilized (3 seconds maximum)

Example 12. Measuring the V/A ratio for the following signal

Video frequency = C55 (743.25 MHz)/Video carrier level = 74 dB μ V (14 dBmV)

Audio subcarrier frequency = 5.5 MHz/Audio carrier level = 64 dB μ V (4 dBmV)



74 dB μ V C55



V/A



V/A= 10dB C55

Leave the V/A mode simply by pressing any key or turning the rotary switch.

4.2.7 Measurement of the C/N ratio



C/N

This function allows the user to measure the ratio of the video carrier level to the noise level present in the channel.

Follow the steps listed below to take this measurement.

1. Tune the video carrier in the channel and wait a few moments until the read level is stabilized.
2. Press the C/N key
3. Wait a few seconds until the measurement is stabilized (maximum 10 seconds)

When the C/N key is pressed, the instrument automatically takes a series of measurements in order to arrive at the closest approximation to the noise level. The time of approximation is a function of the content of the picture that is being transmitted and of the C/N value itself.

When the noise level is lower than the sensitivity of the instrument, a limit value ">" will appear on the display, indicating that the C/N value the user is trying to measure is greater than this limit value.

Example 13. Measuring the C/N ratio for the following signalVideo carrier level = 82 dB μ V (22 dBmV)

Real C/N ratio = 42 dB

C/N ratio measured = 42 dB \pm error (see Appendix E)

82 dB μ V	C45
---------------	-----

C/N

C/N= 42dB	C45
-----------	-----

Display shown after a 5-second wait.

Leave the C/N mode simply by pressing any key or turning the rotary switch.

Example 14. Measuring the C/N ratio of high-quality signalsVideo carrier level = 113 dB μ V (53 dBmV)

Real C/N ratio = 62 dB

C/N ratio measured >53 dB

C/N> 53dB	C45
-----------	-----

The C/N measurement ranges and the accuracy of the measurement are described in Appendix E.

Example 15. Measuring the C/N ratio of low level signals. (<70 dB μ V)

The C/N ratio measurement dynamic is proportional to the video carrier level. So, when the video carrier level is lower than 70 dB μ V, the C/N measurement dynamic does not surpass 40 dB (see Appendix E). If the C/N ratio to be measured is higher than this value, the instrument will indicate it by means of the symbol >.

Video carrier level = 65 dB μ V

Real C/N ratio = 43 dB

C/N ratio measured >34 dB

C/N> 34dB	C19
-----------	-----

4.3 Connection to the computer

The system may be connected to a PC by means of the connection cable which is supplied with option RM-004.



Do not connect any cable other than that supplied by the manufacturer with option RM-004, otherwise serious damage may be caused to the equipment.

1. Prior to connecting the equipment to a PC, disconnect both from their respective power supplies.
2. Connect the end of the connection cable corresponding to the **PROMAX-4** to connection [6] and the other end to the parallel port of your computer. (See the operation manual for the RM-400 for further information).

5 MAINTENANCE

This part of the manual describes the maintenance procedures and the localisation of faults.

5.1 Instructions for returning by mail

Instruments returned for repair or calibration, either within or outwit the guarantee period, should be forwarded with the following information: Name of the Company, name of the contact person, address, telephone number, receipt (in the case of coverage under guarantee) and a description of the problem or the service required.

5.2 Method of maintenance

The method of maintenance to be carried out by the user consists of cleaning the cover and changing the battery. All other operations should be carried out by authorised agents or by personnel qualified in the servicing of instruments.

5.2.1 Cleaning the cover.

CAUTION

To clean the cover, remove the battery from its housing.

CAUTION

Do not use scented hydrocarbons or chlorized solvents. Such products may attack the plastics used in the construction of the cover.

The cover should be cleaned by means of a light solution of detergent and water applied with a soft cloth. Dry thoroughly before using the system again.

CAUTION

To clean the contacts, use a dry cloth. Do not use a wet or damp cloth.

5.2.2 Battery replacement

See paragraph 3.2.

5.2.3 Battery charger fuse

To be replaced by qualified personnel only:

F1: 1 A F 250 V

APPENDIXES

APPENDIX A.- MEASUREMENT OF THE VIDEO CARRIER LEVEL (C_v)

A) Negative Video Modulation (PAL/NTSC)

The measurement of the video carrier level is carried out taking the modulation peak as the measurement value, this being the maximum value of the signal during the line synchronism. The system requires a minimum length of time in order to make this measurement, since it has to detect the peak of the modulated signal.

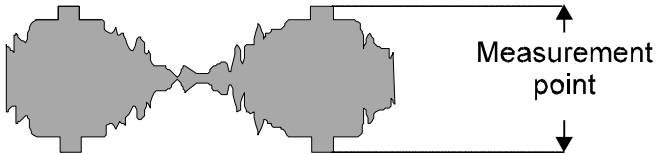

Figure 10.- Measurement of the video carrier level.

The typical values between which the video carrier level fluctuates are:

- In the transmission line: From 70 to 100 dB μ V (From 10 to 40 dBmV)
- In the user's terminal: From 60 to 80 dB μ V (From 0 to 20 dBmV)

B) Positive Video Modulation (SECAM)

On this type of modulation, the line synchronism is determined by a minimum carrier level. The maximum signal level (measurement point) is variable in time, and it is a function of the picture that is being transmitted. It could vary from 10 dB among white and black image; nevertheless white signals, Video Insertion Test (VIT), are transmitted in the sweep pulses, which reduce this margin to 4 dB approximately.

Due to this fact, and the small duration of the VIT, when we measure levels of SECAM signals, it is advisable to add 2 dB to the quantity showed on the display, in order to obtain a measure, its average value, more precise.

APPENDIX B.- MEASUREMENT OF THE ADJACENT CHANNEL LEVEL

The user can obtain the ratio between the video carrier amplitudes of two adjacent channels.

$$C_{LV1} - C_{LV2}(\text{dB})$$

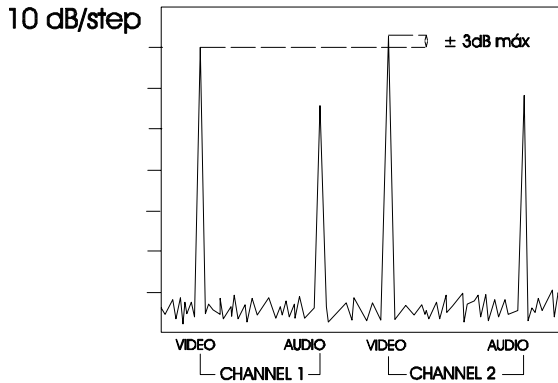

Figure 11.- Measurement of the adjacent channel level.

Differences of more than 3 dB between carriers of adjacent channels may cause problems of interference in reception.

APPENDIX C.- MEASUREMENT OF THE VIDEO / AUDIO RATIO

$$V / A = V_L - A_L \text{ (dB)}$$

It permits to measure the ratio between the video carrier and the audio carrier amplitudes.

Although this process depends on the standard used, it is usual to consider that a properly transmitted PAL channel should have a sound subcarrier 13 dB below the video carrier.

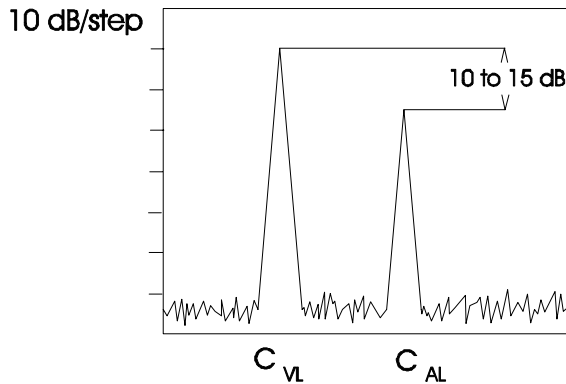

Figure 12.- Video / Audio ratio measurement.

These specifications ensure that there is no interference in the same or the adjacent channel.

APPENDIX D.- CARRIER TO NOISE RATIO (C/N)

The Carrier to Noise ratio is a measurement of the signal quality. The power of the noise measured changes according to the resolution filter utilized. However, in TV it is usual to refer the noise level to a bandwidth of 5 MHz. If the measurement is reduced to a different bandwidth, the user must apply a simple correction. The PROMAX-4 takes the measurement in a noise bandwidth of 5 MHz.

$$C/N = C_L - N_L \text{ (dB)}$$

N_L : depends on the measurement bandwidth

$$N_L = N_{\text{measurement}} + 10 \log (BW_x / BW_{\text{measurement}})$$

There is some standards that determine the minimum C/N value for an installation. In general greater values than 40 dB are considered good quality signals. Lower than 40 dB you can see snow or graininess at the display.

APPENDIX E.- CARRIER / NOISE RATIO MEASUREMENT (C/N)

C/N measurements in modulated carriers

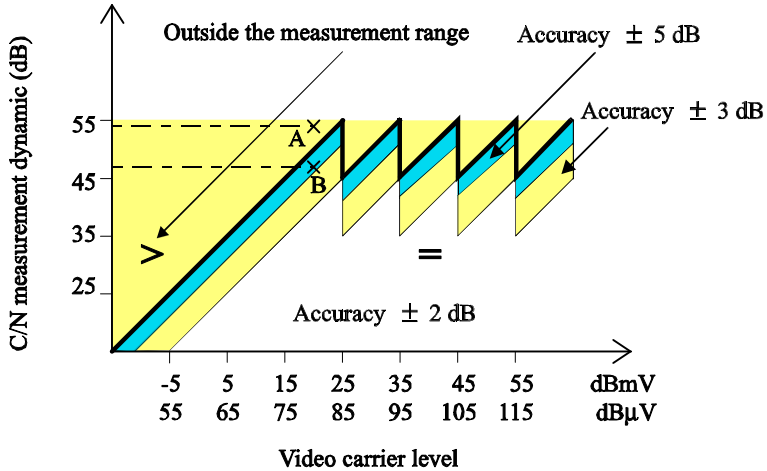

Figure 13.- Video carrier level

Example

Suppose that the video carrier level in a channel, for instance the 45, is of 20 dBmV, from the diagram we can deduce that the measurement range is of 50 dB.

Thus, if when we carry out the measurement the C/N ratio is 54 dB (A) the display will show.

C/N> 50dB C45

On the other hand, if C/N=47 dB (B) we will see on the display.

C/N= 47dB C45

English