

PROPOWER - 5

PLC SPECTRUM ANALYSER



TABLE OF CONTENTS

1	GENERAL	1
1.1	Description	1
1.2	Specifications	2
2	SAFETY RULES	5
2.1	Generals	5
2.2	Descriptive Examples of Over-Voltage Categories	7
3	INSTALLATION	9
3.1	Power supply	9
3.1.1	Battery charge	9
3.1.2	Recommendations for using the battery	10
3.2	Installation and start-up	10
3.2.1	Contrast adjustment	10
4	OPERATING INSTRUCTIONS	11
4.1	Description of the controls and elements	11
4.2	Operating instructions	13
4.2.1	Global configuration menu	14
4.2.2	SCAN operating mode	16
4.2.2.1	SCAN mode configuration	18
4.2.3	CHANNEL-FREQUENCY operating mode	18
4.2.3.1	Channel tuning	19
4.2.3.1.1	Power and C/N ratio measurement of digital PLC channels	19
4.2.3.2	Frequency tuning	21
4.2.3.3	CHANNEL-FREQUENCY mode configuration	21
4.2.4	SPECTRUM ANALYSER operating mode	22
4.2.4.1	SPECTRUM operating mode	22
4.2.4.2	MAX operating mode	23
4.2.4.3	MIN operating mode	23
4.2.4.4	TRANSIENT DETECTOR operating mode	24
4.2.4.5	SPECTRUM ANALYSER mode configuration	24
4.2.5	TILT operating mode	25
4.2.5.1	TILT mode configuration	26
4.2.6	DATALOGGER operating mode	26
4.2.6.1	Datalogger configuration	28
4.3	Connection to a Computer or Printer	29
5	MAINTENANCE	31
5.1	Method of maintenance	31
5.1.1	Cleaning the cover	31
5.1.2	Not replaceable fuses by user	31
	APPENDIXES	33
	APPENDIX A.- FREQUENCY OFFSET ADJUSTMENT FOR TUNING ANALOGUE AND DIGITAL CHANNELS	33
	APPENDIX B.- EVALUATION OF THE FREQUENCY RESPONSE OF MAINS VOLTAGE NETWORKS (LT) FOR PLC TRANSMISSION	34

PCL SPECTRUM ANALYSER PROPOWER-5

1 GENERAL

1.1 Description

The **PROPOWER-5** is six functions in one instrument, **Level Meter**, **Datalogger**, **Scan**, **Tilt**, **Spectrum Analyser** and **Transient Detector** which makes it an excellent tool for the installation and maintenance of **Power Line Communications (PLC)** systems working in the **1 to 50 MHz** range.

As a **Level Meter**, the **PROPOWER-5** enables the following measurements:

Digital PLC channels:

- Channel power measurement by integration
- Carrier / Noise ratio measurement (C/N)
- Level measurement in a frequency

The **Datalogger** function allows up to 55 loggers or measurements to be taken and stored, each with C/N ratios and channel power of up to 140 channels. The measurements obtained may be checked, transferred to a PC or printed at any time.

In **Scan** operating mode, the **PROPOWER-5** indicates the level of all channels present on the band in a bar-graph display. The span and reference level are user definable. A moving marker shows the exact level of each specific channel.

In **Tilt** operating mode, the screen shows, both graphically and numerically, the difference in levels between any four previously defined pilot frequency channels, in order to obtain a qualitative measurement on band equalisation.

As a **Spectrum Analyser** it provides the analysis of the entire band, with a span defined by the user from 1 to 50 MHz. Furthermore, it is possible to alter the reference level, and to detect and maintain the **maximum** and **minimum** values for **INGRESS** measurements.

The **Transient Detector** mode, permits to count the number of impulsive interferences and with a level higher than a threshold defined by the user. The maximum frequency range is from 1 to 50 MHz.

In designing the **PROPOWER-5**, special attention was given to building a multi-purpose, accurate, yet easy-to-use instrument. A simple keyboard gives direct access to the various operating modes and, once in them, any measurement parameter can be easily changed using the rotary selector/button.

In addition, it has an **RS-232C** terminal for connecting to a printer or computer for producing reports on the measurements obtained.

The instrument is powered by means of an internal rechargeable battery.

All these functions have been brought together in one instrument weighing only half a kilo. The ergonomic, sturdy design makes the **PROPOWER-5** a working tool without parallel.

1.2 Specifications

TUNING

Tuning range

From 1 to 50 MHz.

Tuning mode

By channels or by frequency.

Channel plan

10 channel plans, each one with a maximum of 140 channels. Factory start-up channel plans: custom under request⁽¹⁾.

Resolution

10 kHz.

Indication

Graphic LCD with back lighting.

Channel frequency offset

± 2 MHz (10 kHz resolution).

LEVEL MEASUREMENT

Measurement

Digital channels

Power measurement in the channel bandwidth by integration method.

Measuring range

From -80 to 20 dBm.

Maximum input level

From 1 to 50 MHz

25 dBm⁽²⁾.

Reduction of the measurement range depending on the number of channels.

Up to 10 channels

10 dBm.

Readout

Digital in dBm, dBm/Hz and analogue through a graphic bar. 1 dB resolution

IF bandwidth

200 kHz \pm 50 kHz

Input impedance

50 Ω

Audible indicator

Tone which varies with the signal level.

Accuracy

Digital channels

± 3 dB (from 0 to 40 °C) for 2.5 MHz bandwidth channels.

DIGITAL SIGNALS MEASUREMENT

Bandwidth

Switchable.

Frequency tuner

10 kHz.

CARRIER / NOISE RATIO MEASUREMENT

Measurement

Digital channels

Ratio between the channel power and the noise level. The frequency where noise is measured is user definable in absolute or relative value. In the relative mode, the unit takes as default frequency offset the value BW/2.

Measurement range

Digital channels

> 30 dB for input level > -40 dB μ V.

Accuracy

± 2 dB

DATALOGGER FUNCTION

Max. number of loggers	55
Number of channels/logger Measurements	140
Digital channels	Channel power.

SCAN

Span	Variable: 10, 30 MHz and full band (all channels).
Reference level	Variable from -40 to 20 dB μ V in 10 dB steps.

TILT

Indication	Numerical and by level bar.
Analysed band	1 to 50 MHz.
Number of pilots	4 per band.
Pilots frequency	From 1 to 50 MHz configurable.
Pilots resolution	10 kHz.

SPECTRUM ANALYSER

Span	From 1 to 50 MHz (1, 5, 15, 30 MHz and full span).
Reference level	Variable from 60 to 120 dB μ V in 10 dB steps.
Detector	Peak or average.
Bandwidth	200 kHz.
Resolution	
Peak detector	
Span 50 MHz	450 to 460 kHz.
Span 30 MHz	270 to 280 kHz.
Span 15 MHz	130 to 140 kHz.
Span 5 MHz	40 to 50 kHz.
Span 1 MHz	10 kHz.
Average detector	
Span 30 MHz	270 to 280 kHz.
Span 15 MHz	130 to 140 kHz.
Span 5 MHz	40 to 50 kHz.
Span 1 MHz	10 kHz.

TRANSIENT DETECTOR

Detection threshold	From -80 to -40 dB μ V in steps of 1 dB.
Detection range	From 1 to 50 MHz maximum.
Readout	Number of detected transitory in the measuring time. Present detected level and maximum detected level in the time of the measurement.

POWER SUPPLY

NiMh battery	7.2 V.
Low battery indication	Graphic indication on the display: 
Autonomy	Approximately 4 hours (30 % on / off).
Automatic power-off	Power-off after approximately 10 minutes of non-use.
Battery charge	By fast internal charger.
Equipment consumption	8 W.
Mains to charger adapter	230 V / 50-60 Hz / 12 V DC minimum (EUROPE and other countries).

ENVIRONMENTAL CONDITIONS

This equipment could be used on the following environmental conditions, in these conditions the specifications could also be applied:

Altitude	Up to 2000 metres.
Temperature range	From 5 °C to 40 °C.
Maximum relative humidity	80 % (up to 31 °C), decreasing lineally up to 50% at 40°C.

MECHANICAL FEATURES

Dimensions	70 W (90 on the display) x 218 H x 50 D mm.
Weight	825 g. (including battery and holster).

- (1) *Under request carried out at the factory. (See option OP-008-61)*
- (2) *Because of safety reasons, the maximum input power over the entire band is limited up to 25 dBm. The equivalent power level for a group of channels of imilar levels is related with the input power level over the entire band according to the following expression:*
- $$L_T = L + 10 \log N$$
- (L_T : total level , L : mean level of one channel, N : number of channels present).*
- For higher input power levels, the use of an external attenuator of 20 dB is recommended.*
- There may be certain frequencies where the symbol "<" appears at levels higher than -75 dBm (maximum 28 dB). This is due to the automatic correction of the frequency response.*
- The value measured remains correct, although the accuracy becomes ± 3 dB*

INCLUDED ACCESSORIES

AL-101	Mains adapter
AA-012	Car cigarette lighter adapter cable.
0PG4172	PROPOWER-5 Carrying case.
DC-286	Carrier belt.
DC-284	Rubber holster.

OPTIONS

OP-008-61	Change channel plan. (Carried out under request in the factory).
-----------	--

OPTIONAL ACCESSORIES

AD-055	F/female - BNC/female adapter.
AD-056	F/female - IEC/female adapter.
CI-023	Portable serial printer.
CC-208	Data transfer cable to PC or printer.
RM-010	Remote control software for PROPOWER-5.

2 SAFETY RULES

2.1 Generals

- * Use this equipment connected **only to devices or systems with their common at ground potential.**
- * This equipment can be used in **Over-Voltage Category I** installations and **Pollution Degree 2** environments.

the mains adapter is for **INDOOR USE.**
- * When using some of the following accessories **use only the specified ones** to ensure safety.
 - Power adapter
 - Car cigarette lighter adapter
- * Observe all **specified ratings** both of supply and measurement.
- * Use this instrument under the **specified environmental conditions.**
- * The user is not authorised to manipulate inside the instrument:
 - Any change on the equipment should be carried out by qualified personnel.
 - On the Maintenance paragraph the proper instructions are given.
- * Follow the **cleaning instructions** described in the Maintenance paragraph.

* Symbols related with safety:



DIRECT CURRENT



ALTERNATING CURRENT



DIRECT AND ALTERNATING



GROUND TERMINAL



PROTECTIVE CONDUCTOR



FRAME TERMINAL



EQUIPOTENTIALITY



ON (Supply)



OFF (Supply)



DOUBLE INSULATION
(Class II protection)



CAUTION
(Risk of electric shock)



CAUTION REFER TO MANUAL



FUSE

2.2 Descriptive Examples of Over-Voltage Categories

- Cat. I** Low voltage installations isolated from the mains.
- Cat. II** Portable domestic installations.
- Cat. III** Fixed domestic installations.
- Cat. IV** Industrial installations.

3 INSTALLATION

3.1 Power supply

The **PROPOWER-5** is a portable instrument powered by a built-in 7.2 V NiMH rechargeable battery. Before taking any measurement, the user should make sure that the battery is fully charged (use the mains adapter supplied with the instrument).

3.1.1 Battery charge

The instrument has a 230 V / 50-60 Hz, mains adapter, for use in EUROPE and other countries, to power or to charge the instrument. (See accessories to request other types of adapters).

There are two different situations on battery charge:

- 1) With the instrument stopped, on having connected the external power adapter, begins a cycle of fast load which duration will depend on the battery state. For an empty battery this time will be of 3.5 h. approximately. The charging battery indicator on the frontal panel will remain lit in amber colour during this period of time. When the battery charging is completed the indicator will be lit in green colour, to state that now a maintenance charging process begins.
- 2) When the instrument is operating and connects the adapter, this one powers the equipment and provides a battery maintenance charge while the charging indicator remains lit in green colour.

ATTENTION

When stopping the instrument is reinitiated a charge process.

It is for that reason recommendable to discharge the battery using instrument without external power adapter to make complete the charge / discharge process.

ATTENTION

The charge system of PROPOWER-5 incorporates a security system that does not allow the process charge from certain temperature limit, beginning the maintenance charge instead charge mode when the indicator flashes in green/amber until the temperature downs to the required value.

CAUTION

Before using the power adapter, make sure that the adapter is suitable for the mains voltage.

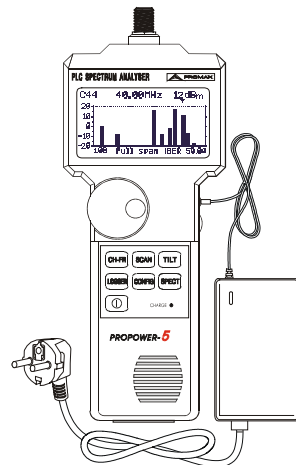

Figure 1.- PROPOWER-5 and mains adapter connection.

3.1.2 Recommendations for using the battery

In case of anticipating a long period of inactivity for the equipment it is recommended to store it with the battery discharged.

When the equipment starts the operation after a long period of inactivity to follow next steps:

- Put to charge the instrument with the external adapter.
- If it starts with the indicator flashing, wait until pass to the charging mode (indicator lighting continuously).
- When starting up the instrument make sure that the AUTO POWER OFF function is OFF, in this case the indicator will be lit in green colour, and then keep it for approximately 10 to 14 hours.

Use the equipment in normal way, reason why after one to three whole cycles of charge/discharge, depending on the time and temperature of inactivity, the battery will have been reconditioned.

3.2 Installation and start-up.

The **PROPOWER-5** has been designed for use as portable equipment.

A fully charged battery can power the equipment for more than three hours. When the low battery indicator appears on the display () , the battery must be recharged.

When a fully discharged battery is installed, it is possible that, due to residual charges, the **PROPOWER-5** may start up. In this case, the instrument will automatically disconnect before the low battery indicator appears on the display.

3.2.1 Contrast adjustment

When turning on the **PROPOWER-5**, if the on/off key [16] is held pushed, on the display will appear the message '**CONTRAST ADJUSTMENT - Turn the rotary selector**', then turning the rotary selector [9] it is possible to adjust the display contrast to get the best viewing according to working conditions. The new contrast value is held when the unit is turned off and when battery is removed.

4 OPERATING INSTRUCTIONS

4.1 Description of the controls and elements

Front panel

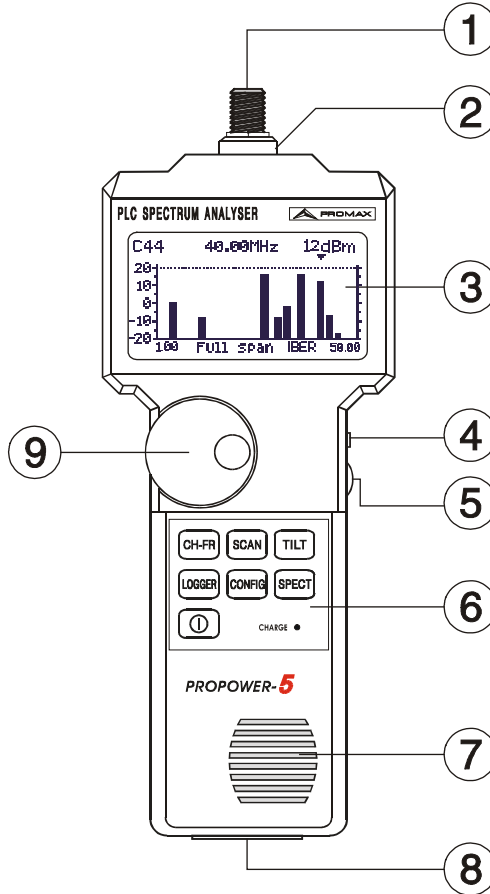

Figure 2.- Front panel.

- [1] F-F (or F-BNC or F-IEC) adapter.



Maximum input voltage level 60 VAC rms /50-60 Hz.

- [2] "F" male base connector.
 [3] Graphic display with back lighting.
 [4] DC power adapter external input.

- [5] Volume control.
- [6] Keyboard. 7 keys for function selection.
- [7] Loudspeaker.
- [8] Connection to computer or printer.

CC-208 specific connection cable.



Do not connect any cable other than that supplied by the manufacturer, otherwise the instrument may suffer serious damage.

- [9] Rotary selector / Push button.

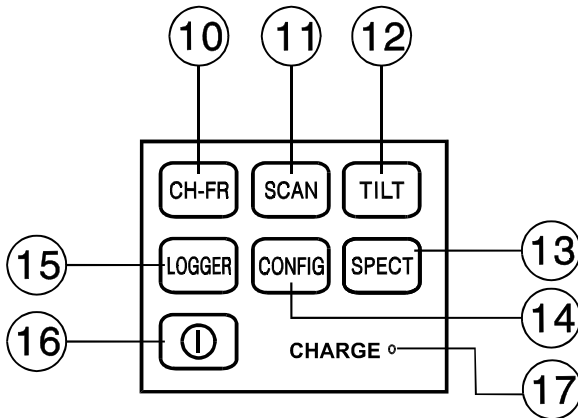









Figure 3.- PROPOWER-5 keyboard.

- [10]  Selects the **CHANNEL - FREQUENCY** operating mode.
- [11]  Selects the **SCAN** operating mode.
- [12]  Selects the **TILT** operating mode.
- [13]  Selects the **SPECTRUM ANALYSER** and the **TRANSIENT DETECTOR** operating modes.

- [14]  Access to **CONFIGURATION** menus specific to each operating mode and to the global configuration menu of the unit.
- [15]  Selects the **DATALOGGER** operating mode. Enables multiple measurements to be taken, visualised, printed or transferred to a PC automatically.
- [16]  On/Off key.
- [17] Battery charge indicator.

4.2 Operating instructions

The **PROPOWER-5** has 6 independent operating modes:

 The **CHANNEL-FREQUENCY** operating mode measures the signal level for a tuned frequency as well as the channel **power** and the Carrier/Noise ratio (**C/N**) for **digital PLC** channels. Press this key to change between channel tuning mode and frequency tuning mode.

 The **DATALOGGER** operating mode enables multiple measurements to be performed and memorised for subsequent checking, transfer to PC or printing. It can perform and store up to 55 obtained measurements or loggers in the memory. Each logger carries out, C/N and channel power measurements on the channels activated in the channel plan (up to a maximum of 140 channels).

 The **SCAN** operating mode shows the signal level of all channels present on the chosen frequency band in a bar-graph display. The span and the reference level may be selected through the rotary selector. In addition, a moving marker shows the numeric level of any specific channel. This mode also permits to define the pilot channels, used for the **TILT** measurement.

 This key permits to accede to 2 operating modes:
 The **SPECTRUM ANALYSER** mode provides a spectrum analysis over the entire band. The span is user definable between 1 and 50 MHz. In addition, it is possible to change the reference level, and **maximum** and **minimum** levels may be detected and held for **INGRESS** measurements.

In the **TRANSIENT DETECTOR** mode, the **PROPOWER-5** operates as a transitory counter in the return path. The level detection threshold and the frequency margin are user definable.

 The **TILT** operating mode shows on the display, both graphically and numerically, the level difference between any four channels, previously defined as pilot channels, in order to obtain information about band equalisation.

To access any operating mode, simply press the corresponding key.

The parameters relative to a particular operating mode can be modified through the **configuration menu associated to the mode**. In order to accede to the configuration menu associated to a particular operating mode, simply press the **CONFIG** key [14]. Some modes have more than one configuration page, to accede to the second page it is necessary to press the **CONFIG** key again. The general parameters of configuration (selecting/editing the channel plan, measurement units, language, etc.) can be changed through the **Global Configuration Menu**, to which it is acceded by pressing again the **CONFIG** key [14]. To leave a configuration menu, just press the key of the operating mode you wish to accede.

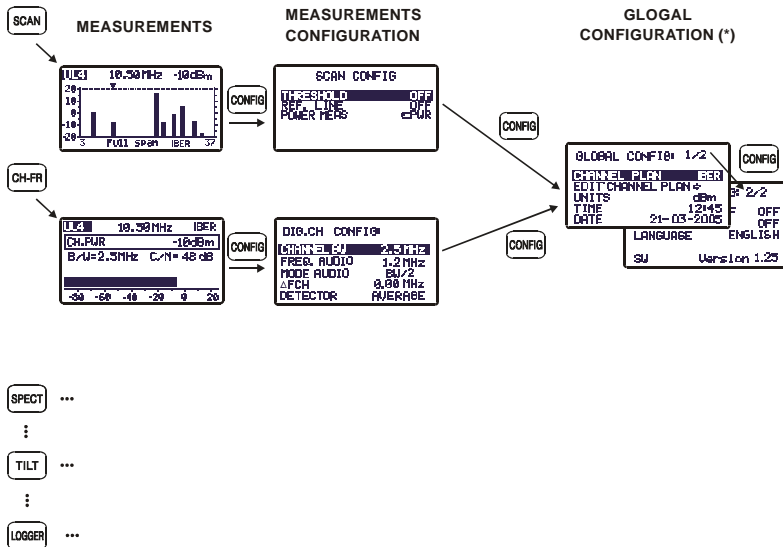

Figure 4.- PROPOWER-5 configuration menus.

4.2.1 Global configuration menu

In order to accede to the global configuration menu, from any operating mode (SCAN, CH-FR, SPECT, etc.), you must press the **CONFIG** [14] key repeatedly (the first time that presses this key accedes to the configuration menu relative to the mode in use, which can have more than one page). The global configuration menu consists of two pages (attached figure shows the first one), to switch from one to the other simply press the **CONFIG** [14] key.



Figure 5.- Global configuration. 1/2.

In order to modify the state of a given parameter, you must turn the rotary selector [9] until this one appears shaded and next press it, then the value of the parameter will appear shaded and turning the selector a new value will be able to be defined. Finally, to validate the new state, press the rotary selector [9] again.

The first page of the global configuration menu permits to modify the following parameters:

a) CHANNEL PLAN

It allows you to choose the active channel plan between the 10 channel plans that unit can store (IBER, etc.).

b) EDIT CHANNEL PLAN.

When selecting this field and pressing the rotary selector, the unit accedes to the active **CHANNEL PLAN**.

The attached figure shows an example of channel plan. The first line shows the name of the channel plan (**IBER** in the figure), the units of measurement (**dBm**). Next line shows the head of the columns that constitute the channel plan: the first column (**CHAN**) shows the name of each channel (UL12, DL13,...) and the second one (**FREQ**) the associated frequency, in MHz. The third column (**BW**) defines channel bandwidth, in MHz. The fourth column (**ON**) activates or deactivates the channel.

IBER		dBm	
CHAN	FREQ	BW	ON AF
ALL			
UL12	3.42	2.00	<input type="checkbox"/> 0.00
DL13	3.42	2.00	<input type="checkbox"/> 0.00
UL14	3.42	2.00	<input type="checkbox"/> 0.00
UL1	4.37	1.75	<input checked="" type="checkbox"/> 0.00
DL4	4.37	1.75	<input checked="" type="checkbox"/> 0.02

Figure 6.- Editing a channel plan.

The maximum number of channels in a channel plan is of 140.

The activation (ON) / deactivation (OFF) of the channels affects to the following operation modes: **CH-FR**, **SCAN** and **DATALOGGER**. When a channel has been deactivated, this one will not be able to be tuned nor to be measured. This property allows to make agile the operation of the **PROPOWER-5**, because it allows to activate only those channels in which we are interested.

The Edit Channel Plan function allows to automatically activate all the channels defined in the channel plan by means of the **ALL** field on the third line. When to the right of **ALL** we select **ON**, all the channels of the plan will be activated, otherwise, if we select **OFF** all channels will be deactivated. In order to activate / deactivate a particular channel, turn the rotary selector [9] until this one appears shaded and then press it, the cursor will jump to the **ON** column, then turning the selector it will be possible to activate it (it appears a cross) or to deactivate it (it does not appear a cross).

Below it appears **ΔFCH** set to 0,00 MHz. In a range from -2,00 MHz to +2,00 MHz. i.e. the displacement of the channel tuning frequency for those channels that present a central frequency displaced respect to the one of the corresponding standard system.

Also this parameter (**ΔFCH**) can be edit in the channel configuration by means of **CONFIG CH-FR** option.

In order to quit the **Channel Edit** press the key associated to the operation mode which you wish to accede.

To modify the rest of characteristics of the channel plans it is necessary to have the **RM-010** software (optional accessory).

c) **UNITS**

The **PROPOWER-5** permits to select the level units between **dBm** and **dBm/Hz**.

d) **TIME**

To enter the time select the **TIME** field and press the rotary selector. Firstly, turn the rotary selector to change the minutes field. Next press the selector again to modify the hours and finally press it once again to confirm the new time.

e) **DATE**

To enter the date select the **DATE** field and press the rotary selector. First change the year field, then the month and finally the day.

The parameters which may be modified on the second page of the global configuration menu of the unit are as follows:

```

GLOBAL CONFIG: 2/2
AUTO POWER OFF  OFF
BEEP            OFF
LANGUAGE        ENGLISH
SW              Version 1.25
    
```

Figure 7.- Global configuration. 2/2.

f) **AUTO POWER OFF**

This field permits to activate (ON) or deactivate (OFF) the POWER-OFF function. When this function is ON, the unit automatically turns off when it has remained inactive for a period of 10 minutes.

g) **BEEP**

This function permits to activate (ON) or deactivate (OFF) the **PROPOWER-5** beeper. When it is on, it sounds on pressing any key or when turning the rotary selector in order to alert the user.

h) **LANGUAGE**

This field permits to select the language between: ESPAÑOL, FRANÇAIS, POLSKI, ENGLISH and DEUTSCH.

IMPORTANT

To leave the global configuration menu, just press the key of the operating mode you wish to accede.

The lower line of the screen shows the **version** of the unit **control software** (1.25 in previous figure)

4.2.2 SCAN operating mode

The **SCAN** operating mode shows, in a single screen, the signal level of all the active channels in the channel plan by means of a bar-graph. In addition, the exact level of any particular channel may be measured by simply placing the marker over it.

To access to this operating mode, press the **SCAN** key [11]. The top line of the screen will display the channel name (UL4), the tuned frequency (10.5 MHz) and the level (-10 dBm) of the channel the marker is over. The marker can be moved by turning the rotary selector [9].

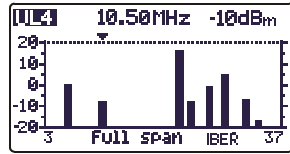

Figure 8.- SCAN mode, full span.

The channel is selected when it is shaded.

To change the **span** (shown bandwidth), press the rotary selector [9] (the span field is activated) and then turn it. The span is variable from the entire band (*full span*) to 10 MHz in the following steps:

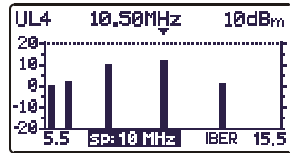

Figure 9.- SCAN mode, span 10 MHz.

1, 5, 15, 30 MHz and full span.

By pressing the rotary selector [9] again, you can change the reference level, in other words, on turning the rotary selector [9] the graph is displaced vertically.

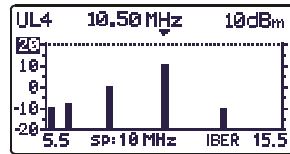

Figure 10.- SCAN mode, Ref. 20 dBm.

To modify the tuned channel, press the rotary selector [9] again, the channel field will be activated and then turning the rotary selector you will be able to change it.

The attached figure shows an horizontal line at -15 dBm. This line allows to establish judgements of channel level acceptance easily. To activate and define this **reference line** see the *Scan configuration menu* (section 4.2.2.1).

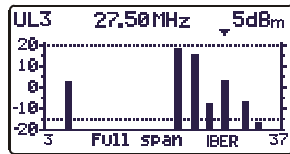

Figure 11.- SCAN mode with reference line at -15 dBm.

In the case of having activated the broadband power detection function (**POWER MEAS -> ΣPWR**) in the configuration menu of **SCAN** mode (See section 4.2.2.1), on the display of **PROPOWER-5** will appear the total power level on the instrument input.

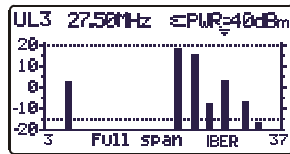

Figure 12.- SCAN mode, power detection function.

This parameter indicates the total power that is being transmitted by the connected cable to the equipment in the band from 1 to 50 MHz.

The **SCAN** operating mode also allows channels to be programmed for use as pilots in **TILT** operating mode, in the forward band (see section 4.2.5 *TILT operating mode*).

IMPORTANT

In order to achieve the maximum accuracy, the digital PLC channels power must be measured always from the CHANNEL-FREQUENCY operating mode.

4.2.2.1 SCAN mode configuration

In the SCAN operating mode, pressing the **CONFIG** key [14] will access the configuration menu for this mode.

This menu permits to change two parameters: **THRESHOLD** and **REFERENCE LINE**. To accede to any of them, turn the rotary selector [9] until it appears shaded and next press the selector, then the value of the parameter will appear shaded and turning the selector you will be able to modify its value. Finally, to validate the new value, press the rotary selector [9] again.

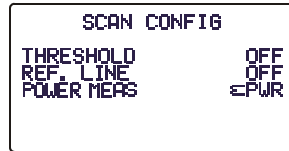

Figure 13.- SCAN configuration menu.

a) THRESHOLD

It defines the minimum level to show channel on the display (OFF or between -20 and 20 dBm). If the threshold is deactivated (OFF), on the SCAN representation will appear all the active channels of the channel plan with a level higher than -20 dBm. Otherwise, if we define a level for the THRESHOLD parameter, channels with a level lower than the threshold value will not be displayed.

b) REFERENCE LINE

It permits to activate or to deactivate (OFF) a reference line on the SCAN graph (between -21 and 20 dBm). This reference line allows to establish judgements of channel level acceptance just with a glance at the SCAN screen.

c) POWER MEAS

It allows to define if the measurement of the power is carried out on the channel bandwidth (**CHAN**) indicates by the **MARKER** or over the full band between 1 and 50 MHz (**ΣMHz**).

IMPORTANT

To leave the SCAN operating mode configuration menu, just press the key of the operating mode you wish to access.

4.2.3 CHANNEL-FREQUENCY operating mode

The **CHANNEL-FREQUENCY** operating mode provides the following measurements:

- Digital PLC channels:**
- Channel power by measurements integration
 - Carrier / Noise (C/N) ratio
 - Level measurement at tuned frequency

To access to this mode of operation, press the **CH-FR** key [10]. There exist two **tuning modes**: by **channel** or by **frequency**. To switch the tuning mode press the **CH-FR** key [10].

4.2.3.1 Channel tuning

4.2.3.1.1 Power and C/N ratio measurement of digital PLC channels.

When a PLC digital channel is tuned, the **PROPOWER-5** will display a screen as the one shown in the attached figure.

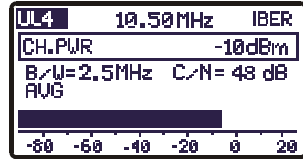

The tuned channel (UL4 in the figure) appears in the higher left hand corner; this may be changed by turning the rotary selector [9]. At its right appears the frequency (10.50 MHz) and the active channel plan (IBER in the figure).

Figure 14.- Measuring a digital channel.

Below a screen as shown in the attached figure will appear. This screen shows the digital **CHANNEL POWER** (-10 dBm in the example) together with its related channel bandwidth (**BW=2.5 MHz**) and the **Carrier/Noise ratio (C/N=48 dB)**. At the bottom of the screen a bar-graph represents the channel power, with a resolution of 1 dB.

VERY IMPORTANT

In order to measure digital channels correctly, previously, the channel must be configured (see Edit Channel Plan function at section '4.2.1 Unit Global Configuration), if necessary, the CHANNEL BW parameter should be redefined by means of the Channel-Frequency configuration menu. When a channel has been defined as digital, the PROPOWER-5 tunes it at its central frequency.

Digital channels power measurement is carried out by means of an integration method. The **PROPOWER-5** divides the bandwidth of the channel (**CHANNEL BW**) in sections of 230 kHz (4 by each MHz approximately) and measures the contribution of each one to the total power of the channel. This way, a very exact measurement is obtained, specially in the case of degraded channels, because the channel flatness is had in consideration.

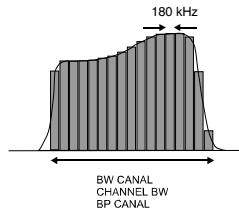

Figure 15.- Measuring the power of a digital channel by integration.

The **C/N ratio** measurement shows the ratio between the digital PLC channel power and the noise power. The user can define the frequency where the noise power must be measured. Two possibilities exist:

I. Absolute method

Selecting in the Channel-Frequency configuration menu the **NOISE MODE** parameter as **FREQ.**, the equipment will interpret the **NOISE FREQ.** value as the frequency where the noise power measurement must be done. Naturally the user must be sure that the **NOISE FREQ.** value corresponds with a free channel.

II. Relative method

Selecting in the Channel-Frequency configuration menu the **NOISE MODE** parameter as **F**, the unit will make the measurement of noise at the frequency obtained to add to the tuning frequency (channel central frequency) the value defined for the **NOISE FREQ.** parameter. The **PROPOWER-5** takes by default **NOISE FREQ. = BW/2**, where **BW** is the channel bandwidth defined in the channel plan, thus for example, if it is desired to measure the C/N ratio of a digital PLC channel with a bandwidth (**BW**) of 2.5 MHz, **NOISE FREQ.** will take as value 1.25 MHz. The Channel-Frequency configuration menu (paragraph 4.2.3.3) allows the user to redefine this parameter; when tuning a new channel the equipment will return to assign to **NOISE FREQ.** the default value.

The following figure shows that when making C/N measurements in the relative method (ΔF), it is essential to bear in mind the presence of adjacent channels; otherwise, the noise could be confused with the signal of another channel.

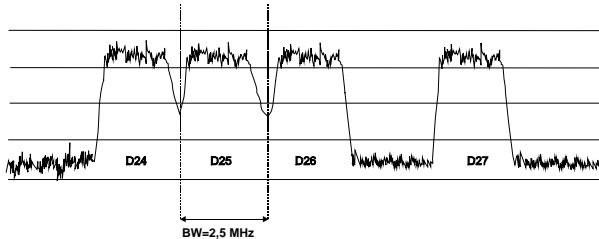

Figure 16.- Example of digital channels spectrum.

Taking as example the previous figure, if we suppose that for the channels that appear in the figure it has defined a bandwidth of 2.5 MHz, in the relative mode of measurement the **PROPOWER-5** will take as value for **NOISE FREQ. = 1.25 MHz**. Note that this method can cause erroneous measures in the measurement of the channels.

For **D24** it is advised to configure **NOISE FREQ. = -1.75 MHz** and to verify if the measurement increases. In case a channel has two adjacent channels (for example channel **D25**) it is recommended to select the absolute mode and to assign to the **NOISE FREQ.** parameter a frequency corresponding to a free channel (for example between **D26** and **D27**).

4.2.3.2 Frequency tuning

When in **CHANNEL-FREQUENCY** operating mode, pressing the **CH-FR** [10] key switches **tuning by channel** to **tuning by frequency** and vice versa. In the **tuning by frequency mode** in the case that **LEVEL** mode has been selected (see section "4.2.3.3 CHANNEL-FREQUENCY mode configuration") the instrument becomes a receiver with a resolution of 10 kHz in the 1 to 50 MHz band. In this mode you may tune to any signal within the band, including leakage pilots, telephone and communications signals. To change tuning simply press the rotary selector [9] until the digit you want to change is underlined and then turn the rotary selector [9]. The channel number will appear to the left of the tuning frequency, as long as it corresponds to an active channel.

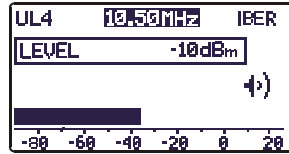

Figure 17.- Frequency tuning.

Remark: When switching from frequency to channel, if the tuned frequency does not correspond to any channel, the **PROPOWER-5** will search for the channel nearest to this frequency and will stay tuned to this channel. This operation may take a few moments.

4.2.3.3 CHANNEL-FREQUENCY mode configuration

In **CHANNEL-FREQUENCY** mode, pressing the **CONFIG** key [14] will access the first page of the configuration menu of the parameters relative to this mode.



Figure 18.- Configuration.

The parameters which may be changed and their margins are shown in the following table. To change a given parameter turn the rotary selector [9] until the field is activated (it will appear shadowed) and then press. The value of the parameter will be activated and may be changed by turning the rotary selector. When the value you want appears, press the rotary selector [9] to validate it.

DESCRIPTION	PARAMETER	VALUES
(only when tuning by frequency) Frequency steps	FREQ. STEP	From 0.01 to 10.00 MHz
Digital PLC channel bandwidth	CHANNEL BW	From 0.3 to 9.9 MHz
Frequency where noise is measured in the C/N measurement.	NOISE FREQ.	±9.9 MHz (relative mode). 1.00 MHz to 50.00 MHz absolute mode.
Noise measuring mode.	NOISE MODE	FREQ (Absolute): Noise level is measured at the frequency defined by NOISE FREQ. ΔF (Relative): The value defined by NOISE FREQ. is added to the tuning frequency.

DESCRIPTION	PARAMETER	VALUES
Power measurement in digital channel	DETECTOR	AVERAGE: Power measurement in digital channel by integrating method. PEAK: Power measurement maximum in digital channel.
(only when tuning by frequency) Frequency mode	MODE FREQ.	LEV: Level measurement. DIG: Power integration.

The parameters **CHANNEL BW** and **NOISE FREQ.** are changed digit by digit, starting at the lowest weight.

Finally, **ΔFCH** parameter allows to set the frequency offset for the channel tuning (**PROPOWER-5** admits values from 2.00 to -2.00 to MHz), i.e. the displacement of the channel tuning frequency for those channels that present a central frequency displaced respect to the one of the corresponding standard system.

Also this parameter (**ΔFCH**) can be edit in the channel configuration by means of **CONFIG CH-FR** option.

IMPORTANT

To leave the configuration menu of the CHANNEL-FREQUENCY mode, just press the key of the operating mode you wish to access.

4.2.4 SPECTRUM ANALYSER operating mode.

Pressing the  key the unit switches to the SPECTRUM ANALYSER mode. This function has 4 different operating modes (SPECT, MAX, MIN and TRANS), which are selectable through the spectrum mode configuration menu (see section 4.2.4.5).

4.2.4.1 SPECTRUM operating mode.

In the **SPECTRUM** mode, the **PROPOWER-5** provides a spectral analysis of the band; the span and the reference level are variable. The spectral analysis can be done in the band from 1 MHz to 50 MHz. The spectrum configuration menu (section 4.2.4.5); this menu also allows to select the **detector** used for the representation of the spectrum between **peak** and **average**.

The marker frequency is displayed in the higher left hand corner of the screen (25.00 MHz) and, to its right, the frequency signal level (-6 dBm). To alter the marker frequency turn the rotary selector [9].

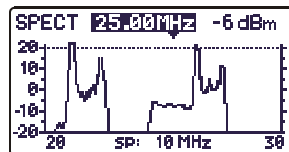

Figure 19.- SPECT mode.

By pressing the rotary selector [9] you can alter the **span** between 1 MHz and 50 MHz.



Figure 20.- SPECT mode, span reduction.

By pressing the rotary selector [9] again the reference level may be modified.



Pressing the rotary selector [9] a second time will activate the tuning frequency field of the marker, being possible to tune new frequencies.

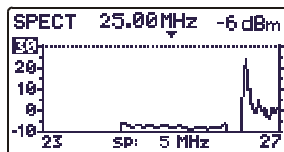

Figure 21.- Reference Level modification.

The attached figure shows an horizontal line at 45 dBm. This line allows to identify levels over a reference of our interest easily. The activation and definition of this **reference line** is carried out on the spectrum analyser configuration menu.

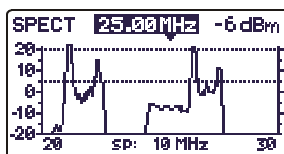

Figure 22.- Reference line.

4.2.4.2 MAX operating mode.

The SPECTRUM operating mode also permits to be configured as **maximum hold** (MAXIMUM INGRESS). This option is selected on the Spectrum Configuration menu (section 4.2.4.5). In the **MAX** mode, the **PROPOWER-5** holds on the screen the maximum measured level through a dotted line.

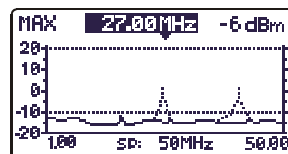

Figure 23.- MAX mode.

This measurement permits to detect intermittent interferences.

Since on this operation mode the **PROPOWER-5** holds on the screen the maximum measured value (through a dotted line), after making several measurements over the band, it will be possible to detect impulsive type interferences. It is advised to previously define a reference line which actuates as a maximum noise threshold (-10 dBm on previous figure).

4.2.4.3 MIN operating mode.

This measurement permits to detect permanent channel interferences that in an other way could remain masked because of the variable nature of the signal.

To select this representation mode you must select the **MIN** mode, MINIMUM INGRESS (see section 4.2.4.5. *Spectrum mode configuration menu*).

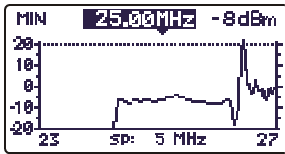

Figure 24.- MIN mode. First scan.

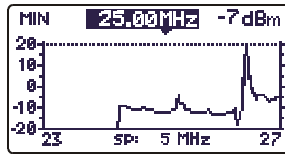

Figure 25.- After several scans.

Previous figures show an example of this measurement over a digital PLC channel. Left figure corresponds to the first sweep. After several sweeps (right figure) an interference is seen at the centre of the channel, which previously remain masked by the noisy nature of the signal.

4.2.4.4 TRANSIENT DETECTOR operating mode

The TRANSIENT DETECTOR mode allows to count the number of transitory with a level higher than a certain threshold. The threshold is defined by the user (between -80 and -40 dBm) as well as the detection frequency range.

The **SCAN** field shows the margin of frequencies on which the detector acts (the higher frequency can be reduced by means of the **STOP. FREQ.** parameter on the configuration menu).

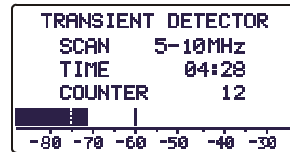

Figure 26.- Transient detector mode.

The lower line (**TIME**) shows the time since the detector is active.

The **COUNTER** field shows the number of impulses that have exceeded the level defined by the **REF. LINE** parameter in the configuration menu of the SPECT mode (section 4.2.4.5).

To initialize the TIME and COUNTER fields, press the **SPECT** [13] key.

In the lower part of the screen it appears a bar that shows present level, a dotted line shows the detection threshold (REF. LINE) whereas the continuous line indicates the maximum detected level.

4.2.4.5 SPECTRUM ANALYSER mode configuration

Pressing the **CONFIG** key [14] will access the parameter configuration menu for the **SPECTRUM** function.

CONFIG

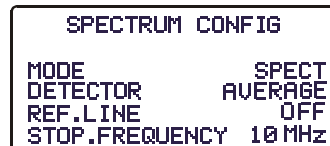

Figure 27.- SPECT mode configuration.

To change the value assigned to one parameter, turn the rotary selector [9] until its field is activated (this will appear shadowed) and then press. The value of the parameter will be activated and may be changed by turning the rotary selector. When the value you want appears, press the rotary selector [9] to validate it.

The parameters that can be modified through this menu are:

a) MODE

It selects the representation mode:

- SPECT** Instantaneous value.
- MIN** Minimum values held (MIN INGRESS).
- MAX** Maximum values held (MAX INGRESS).
- TRANS** Transient detector.

b) DETECTOR

It selects the used detector between:

- AVERAGE** (Max. SPAN = 30 MHz).
- PEAK**

c) REF. LINE

It permits to activate / deactivate and to define the reference line level in 1 dB steps from -80 to -40 dBm. This line appears on the spectrum representation and also it is the threshold value for the impulses detection in the TRANSIENT mode (only if its value is under -40 dBm).

d) STOP. FREQ

It defines the maximum frequency for the transient detection.

IMPORTANT

To leave the configuration menu of the SPECT mode, just press the key of the operating mode you wish to access.

4.2.5 TILT operating mode.

The **TILT** operating mode displays on-screen, graphically and numerically, the difference in level between any four frequencies previously defined as pilots. This function provides a quantitative measurement about band equalisation.

To access this mode of operation press the **TILT** key [12]. The screen will show a bar-graph of the four pilot channels and the difference in level (TILT) between the upper pilot and the lower pilot (- 5 dB in the example). When the pilots are not present or its level is lower than 20 dBm, the message 'NO PILOTS' will appear. Turning the rotary selector [9] the reference level may be modified.

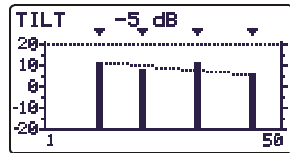

Figure 28.- TILT mode.

The pilots may be defined in two ways:

a) By frequency

Using the TILT configuration menu. See section 4.2.5.1 Tilt mode configuration.

b) By channel

From the **SCAN** mode. In order to do this:

1. Place the marker over the channel you want as low pilot.
2. Press the **SCAN** key [11], and the message '**PILOT 1: PRESS TILT**' will appear at the bottom of the screen.
3. Keeping the **SCAN** key [11] held down, press the **TILT** key [12], and a message '**PILOT 1 ENTERED**' will appear as confirmation.

Repeat the steps 1 to 3 for the 3 following pilots.

4.2.5.1 TILT mode configuration.

Pressing the **CONFIG** [14] key will access to the first page of the configuration menu.

CONFIG	TILT CONFIG:	
	PILOT 1	4.37 MHz
	PILOT 2	27.25 MHz
	PILOT 3	35.07 MHz
	PILOT 4	48.00 MHz

Figure 29.- TILT configuration.

To change a given parameter turn the rotary selector [9] until the field is activated (this will appear shadowed) and then press. The value of the parameter will be activated and may be changed by turning the rotary selector. When the value you want appears, press the rotary selector [9] to validate it.

a) PILOT 1

It defines a frequency belonging to the band (from 1 to 50 MHz) where the first measurement of level will be done. This parameter, and the rest of pilots, is defined digit by digit, by pressing repeatedly and turning the rotary selector.

b) PILOT 2

It defines the second pilot frequency belonging to the band.

c) PILOT 3

It defines the third pilot frequency belonging to the band.

d) PILOT 4

It defines the fourth pilot frequency belonging to the band.

IMPORTANT

To leave the configuration menu of the TILT mode, just press the key of the operating mode you wish to access.

4.2.6 DATALOGGER operating mode.

The **LOGGER** function permits to automatically measure, the Carrier/Noise ratio as well as the power channel measurements of each active channel in the channel plan (see paragraph Channel Plan editor at section 4.2.1. *Unit Global Configuration*). These measurements are stored in the memory so that they can be subsequently viewed, printed or transferred to a PC. The **PROPOWER-5** will store up to 55 obtained channels or loggers in the memory, with a maximum of up to 140 analysed channels in each.

When pressing the **LOGGER** [16] key, a screen similar to the one of the attached figure will appear. The first line shows the logger number (i.e. 53 in the attached figure) followed by the date it was acquired (only if MEASURE function was executed on that logger previously). Below, the different functions you can perform from this operating mode are shown: **VIEW**, **MEASURE** and **PRINT**.

LOGGER

```

LOGGER NUMBER      53
                  10-10-04
VIEW
MEASURE
PRINT
14:52:22          14-11-04
    
```

Figure 30.- LOGGER function. Initial menu.

On the bottom of the display appears present time and date. To modify them see section 4.2.1 *Global Configuration Menu*.

To accede to any of the different fields of the initial screen of the **LOGGER** function, turn the rotary selector [9] until it is activated (it appears shadowed) and next press it.

First of all you must select the logger on which you want to perform any function: turn the rotary selector until the **LOGGER NUMBER** field is shadowed and press it. Then turning the rotary selector, select the desired logger (from 0 to 54) and finally press it again to validate. The acquisition date appears under the logger number (only if you have taken measurements on this logger).

To carry out a logger acquisition you must select the **MEASURE** function, for this purpose turn the rotary selector [9] and when this field appears shadowed press it, in this way you will accede to the logger. Next press again the rotary selector [9] in order that the **PROPOWER-5** makes all the measurements defined in the **LOGGER** configuration menu over all the active channels of the channel plan (see *Edit Channel Plan* function at section 4.2.1 *Global configuration menu*).

IMPORTANT

The parameters to make the measures as the frequency offset for the noise measure of the digital PLC channels C/N ratio, will correspond with the configuration of the equipment at the time of carrying out the measurement.

To return to the initial menu of the **LOGGER** function press the **LOGGER** key.

To check the measurements stored in a specific logger select the **VIEW** option:

The first line shows the channel plan (IBER in the example), and the units of measurement (dBm). The second line shows the logger number (53 in the attached figure) and the headings of the measurements (**PWR** and **C/N**). The measurements taken are shown in the following format: first column shows the channel, the second column shows the channel power (digital PLC channels), the third the fourth the C/N ratio. Turning the rotary selector [9] you can see the rest of channels.

```

IBER              dBm
LIS:53           PWR      C/N
UL12             23      <
DL13             21      <
UL14             21      <
UL1              46      15
DL4              < 20      21
UL5              12
    
```

Figure 31.- Viewing a logger.

The time and date when measurements were taken appear at the end of the list of measurements, in the following order: hour:minute:second and month:day:year. To return to the initial menu of the **LOGGER FUNCTION** press **LOGGER** key.

To print the stored measurement select the **PRINT** field, previously consult section 4.3 *Connecting to a computer or a printer.*

```

PROPOWER-5
-----
LOGGER NUMBER          10
DATE: 08:55           12-09-2004

CHANNEL PLAN:         IBER
UNITS:                dBm
THRESHOLD:            OFF
NOISE FREQ.:          BW/2

CHAN   FREQ      PWR      C/N
UL12   3.25      16       52
DL13   3.25      13       33
UL14   3.25     -10       15
UL1    3.75     -15       18
DL4    4.37      20       44
UL5    6.50     -18       20
DL6    6.50      11       34
DL12   6.75      19      >37
UL13   6.75      20      >42
DL14   7.37     -13       10
UL7    7.75     -16       13
DL8    7.75
    
```

Figure 32.- Example of print.

4.2.6.1 Datalogger configuration.

From the **LOGGER** mode, when pressing the **CONFIG** key [14] we will accede to the configuration menu. This menu permits to modify the **THRESHOLD** and **MEASURES** parameters. To accede to them turn the rotary selector and once the parameter we want to change is appears shadowed, press it; then turning it its value will be modified. Finally press it again to validate the new value.

CONFIG	LOGGER CONFIG
THRESHOLD	OFF
MODE	PWR/CN

Figure 33.- Logger configuration menu.

a) THRESHOLD: It activates / deactivates the measurement threshold.

This parameter allows to carry out the logger function in an agile way, by activating only those measures we consider significative. In the **OFF** mode (deactivated) all measurements are taken (with a level higher than 0 dBm). On the other hand, when a level is defined, only those channels with a level higher than the **THRESHOLD** value will be measured.

b) MODE: It defines the types of measurements to be taken.

This parameter allows to select the measurements that are desired to made between:

- **POT**: Potencia detectada en el conal digital PLC
- **POT/CN**: Level and Carrier to Noise ratios.

REMARK

*The measurements carried out on **CH-FR** operating mode are more actual since they are taken using an integration procedure and they consider the whole channel spectrum.*

IMPORTANT

To leave the configuration menu of the DATALOGGER mode, just press the key of the operating mode you wish to access.

4.3 Connection to a Computer or Printer.

The **PROPOWER-5** permits the connection to a PC or to a serial printer for data transfer, by means of the connection cable model **CC-208**.

Do not connect any cable other than that supplied by the manufacturer, otherwise serious damage may be caused to the equipment.

- 1) Prior to connecting the equipment to a PC, disconnect both from their respective power supplies.
- 2) Connect the end of the connection cable corresponding to the **PROPOWER-5** to connection [8] and the other end to the serial port of your computer or printer.

Once the computer or printer have been connected, select on the **PROPOWER-5** the **LOGGER** operation mode. If **PRINT** function is selected data will be dumped to the remote unit through the serial port.

The communication parameters used by the **PROPOWER-5**, and which therefore must be defined on the remote unit (PC or printer) are the following:

Rate	19200 bauds
Data bits	8 bits
Parity	None
Stop bits	1

The remote control software **RM-010** (optional accessory) permits to carry out from a computer the following options:

- 1) CHANNELS PLAN PROCESSOR: Modify, add or delete channel plans.
- 2) CONFIGURATION: Permits to modify all the configuration parameters.
- 3) DATALOGGER: Permits to edit and to save all the measurement contained in a logger.
- 4) UPDATE: Allows to update the PROPOWER-5 software version.

5 MAINTENANCE

This part of the manual describes the maintenance procedures and the location of faults.

5.1 Method of maintenance

The method of maintenance to be carried out by the user consists of cleaning the cover and changing the battery. All other operations should be carried out by authorised agents or by personnel qualified in the servicing of instruments.

5.1.1 Cleaning the cover.

CAUTION

Do not use scented hydrocarbons or chlorized solvents. Such products may attack the plastics used in the construction of the cover.

The cover should be cleaned by means of a light solution of detergent and water applied with a soft cloth. Dry thoroughly before using the system again.

CAUTION

To clean the contacts, use a dry cloth. Do not use a wet or damp cloth.

CAUTION

Do not use for the cleaning of the front panel and particularly the viewfinders, alcohol or its derivatives, these products can attack the mechanical properties of the materials and diminish their useful time of life.

5.1.2 Not replaceable fuses by user

To be replaced by qualified personnel. Its position identifier and characteristics are:

F001:	FUS	0.5 A	T	125 V
F002:	FUS	2.5 A	T	125 V

APPENDIXES

APPENDIX A.- FREQUENCY OFFSET ADJUSTMENT FOR TUNING ANALOGUE AND DIGITAL CHANNELS.

It is possible to introduce an offset of the tuning central frequency for the channels defined in each channel plan using the ΔFCH parameter (± 2 MHz). Therefore, it is possible to adapt the measures to irregular tunings, due to small displacements on channel central frequencies that are defined by the standard channel plan.

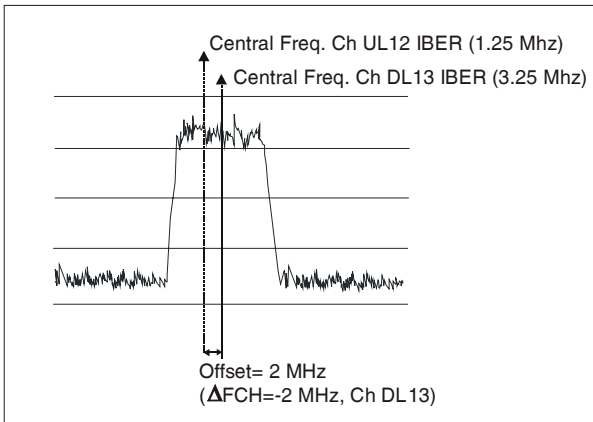

Figure 34.- Frequency offset on the tuning central frequency.

Taking as example the previous figure, if we suppose that in the configuration parameters of the digital PLC channel (CH DL13) a frequency offset equals to 2 MHz has been defined for the channel tuning frequency ($\Delta FCH = -2$ MHz), although the central frequency corresponding to channel CH UL12 (1.25 MHz) does not match with the defined one for the current IBER channel plan CH DL13 (3.25 MHz), it will be possible to take measures corresponding to the standard IBER channel plan (CH UL12, 1.25 MHz) with no need to modify the current channel plan or to enter a new one.

APPENDIX B.- EVALUATION OF THE FREQUENCY RESPONSE OF MAINS VOLTAGE NETWORKS (LT) FOR PLC TRANSMISSION

The Power Line Communication technology (**PLC**) uses the electrical distribution lines for the transmission of information in broadband.

From the distribution centers up to each subscriber the energy is distributed as low frequency alternate current (50 or 60 Hertz) by means of a Low Voltage between 220 and 440 V.

PLC technology uses the Low Voltage network at high frequencies between 1.6 and 30 MHz to transmit information. In this data transmission three networks take part: IP network or transport network, Distribution network or Medium Tension (**MT**) and the Access network or Low Tension (**LT**).

PLC Connection

In order to use this technology the following devices are necessary:

- **PLC Modem.** Is the device installed in the home of the subscriber who allows to the data transmission and voice.
- **Repeater.** is installed generally in the consumption meters room of the company, neighbourhood or parcel of houses and is the device that is connected with the user modem. Its main function is to regenerate **PLC** signals.
- **Head End device.** This device located in the electrical centrals communicates with the repeaters. These equipments are prepared to connect with IP networks (Ethernet).

The **PLC** network topology consists of connecting the modem to Low Voltage by the user, so that this device communicates with the repeater located in the consumption meters room.

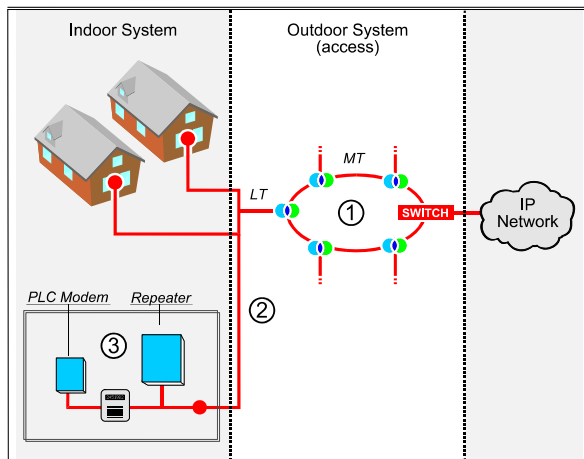

Figure 35.- PLC measurement sections.

It is possible to easily canalise a certain electrical distribution network and to evaluate if it is adapted for the **PLC** signal transmission from a simple procedure of test that is made by means of the noise generator **PROPOWER-1** and the **PLC** spectrum analyser **PROPOWER-5**.

This procedure allows to evaluate PLC signals in three steps from the electrical distribution lines:

1. MT Ring
2. BT Lines, being this the most important line to be checked.
3. Domestic Line, from the consumption meter to the subscriber.

Measurement procedure

1. Connect the **PROPOWER-1** generator in the point of measurement and to activate it.
2. Connect the **PROPOWER-5** analyser in the different points of connection.
3. Verify if the measured spectrum presents acceptable insertion losses, according to the preset tolerance levels for each section that allow their use in the transmission of **PLC** signals. Also it is valid to identify the different lines of communication characterising them from the spectrum measured.