

SATHUNTER DVB-S/S2 SATELLITE HUNTER

The SATHUNTER is an instrument designed for the installation of Direct To Home (DVB-S/S2) satellite reception systems. It is fully automatic and very easy to use. Just turn the dish and the instrument will show up the identification of the selected satellite when it is detected. The instrument is actually reading the information transmitted by the satellite and displays its orbital position and the service list.



USB REMOTE CONTROL



Easy to use



1.-Detection

It detects signal from any analogue or digital satellite thanks to the built-in wide band detector. In this mode the meter behaves like a satfinder and shows information about the received signal power in the form of two graphic bars with two different time constants and an audible indicator.

2.- Identification

Once a satellite signal has been found it is possible to confirm with no possibility of error if the received satellite corresponds to the one desired. To do that the SATHUNTER reads information from the transport stream tables at the preprogrammed test frequencies.

3.- Adjustment

It allows to make proper digital measurements such as channel power, MER or CBER. All information is displayed on the screen in a very convenient way so that optimising dish alignment becomes really easy. MER and CBER in particular are shown in numbers and a graphic bar as well.

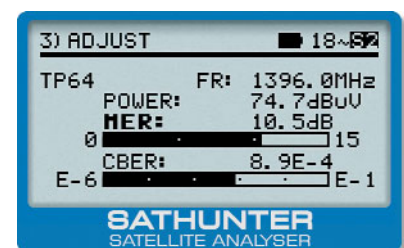
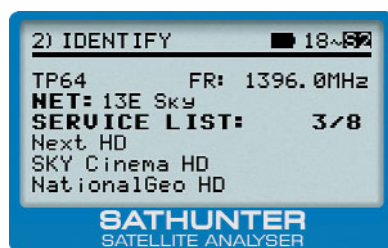
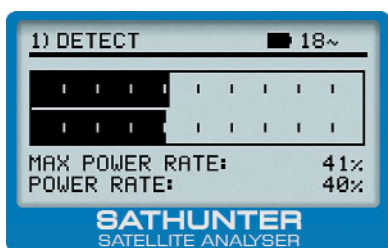

DVB-S/S2 SATELLITE HUNTER

Selective identification

The equipment can be programmed for a specific application, dish alignment for a specific satellite for instance. This could be the case of installers working for a particular DTH platform that want to eliminate any possibility of error and the related waste of time. Equipment settings can be modified at will using a PC computer and the supplied software.

Identification of up to 16 satellites

In **IDENTIFICATION** (2) mode, the equipment reads the information it receives from the satellite, presenting the orbital position and name of the service or satellite for a maximum of 16 satellites that can be programmed as the user deems appropriate.

Detection of short circuits and protection

The equipment allows detection of excessive LNB consumption. Outages in the cable or faulty LNB operation will be indicated by the equipment. It also has a short circuit detection feature.

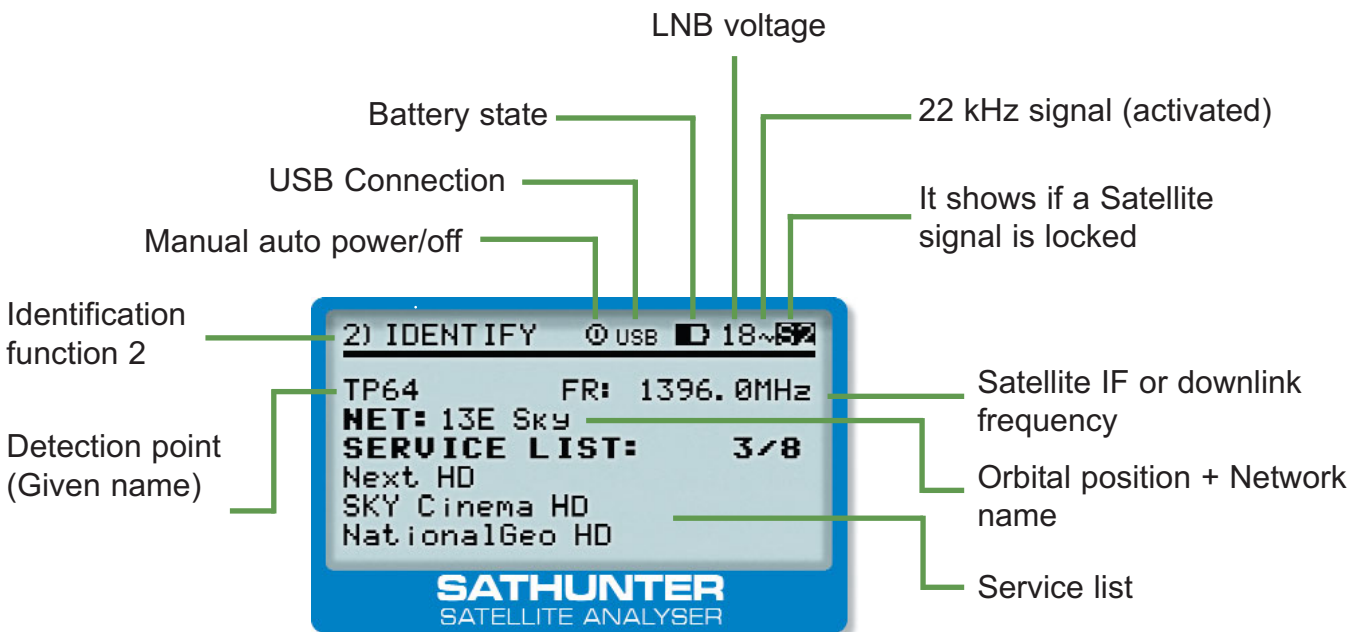

Long-life battery (Li-Ion)

Given the high consumption of LNBs, one of the fundamental features for this type of portable instrument is battery operating time.

The **SATHUNTER** has been designed to allow continuous supply to universal LNB for over two hours.

Battery charging time is about 2 hours

but 70% of the total battery capacity is recovered in the first hour thanks to Li+ technology. Using the adapter cable shipped with **SATHUNTER**, the equipment can be charged from a vehicle's cigarette lighter in route to jobs.

A universal charger is also delivered with the equipment.

It uses a very comfortable replaceable RF input connector. The instrument comes with a hard transport case.

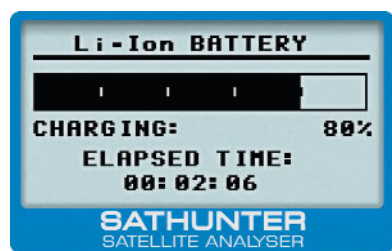

Rough Construction

All details have been taken into account in the design of the **SATHUNTER**.

It is a portable meter for outdoor use with a water resistant front panel and a sturdy ABS case.

SPECIFICATIONS	SATHUNTER
TUNING Frequency range Measurement points	950 MHz to 2150 MHz 16 maximum
RF INPUT Impedance Connector Level range Maximum signal level	75 Ω Universal, including BNC, DIN and F interchangeable adapter 30 dB μ V to 110 dB μ V 120 dB μ V
DVB-S SIGNAL PARAMETERS Symbol rate Roll-off (α) factor of Nyquist filter Code Rate Spectral inversion	2 to 45 Mbauds 0.35 1/2, 2/3, 3/4, 5/6, 7/8 Selectable: ON, OFF
DVB-S2 SIGNAL PARAMETERS Symbol rate (QPSK) Symbol rate (8PSK) Roll-off (α) factor of Nyquist filter Code Rate (QPSK) Code Rate (8PSK) Spectral inversion	2 to 33 Mbauds 2 to 30 Mbauds 0.20, 0.25 and 0.35 1/4, 1/3, 2/5, 1/2, 3/5, 2/3, 3/4, 4/5, 5/6, 8/9, 9/10 3/5, 2/3, 3/4, 5/6, 8/9, 9/10 Selectable: ON, OFF
DVB-S / S2 MEASURES	Power: 40 to 100 dB μ V 0 to 25 dB CBER: 1E-6 to 1E-1 VBER (DVB-S only): 1E-8 to 1E-3 LBER (DVB-S2 only): 1E-8 to 1E-3
SIGNAL PARAMETERS Spectral inversion Quality level for acceptance Initial values Displayed information Configuration of measurement points	Automatic Definable by user MER = 5 dB Satellite's Azimuth and orbital position if it is detected. Service name, the 32 first services and network or bouquet, if it is detected. Visual indication of DVB-S or DVB-S2 synchronized signal. By serial connection to PC (cable and program included)
EXTERNAL UNITS POWER SUPPLY Output voltage Maximum output current 22 kHz signal Voltage Frequency	Through the RF input connector 13 V, 18 V \pm 1 V 300 mA Selectable 0.6 V \pm 0.2 V 22 kHz \pm 4 kHz
BACK-LIGHT DISPLAY	Automatic
POWER SUPPLY Battery Low battery indication Charger Autonomy Charging time Mains Adapter	7.4 V 2.2 Ah Li-Ion battery Acoustic indication and a message on the display Built-in. It disconnects the powering when the charging process ends 80 min. typically, powering a universal LNB and identifying a signal continuously 100 min. approx. (*) 90 - 250 V/50-60 Hz (included), 12 V DC, 20 W
OPERATING ENVIRONMENTAL CONDITIONS Altitude Temperature range Max. relative humidity	Up to 2000 m. From 5 $^{\circ}$ C to 40 $^{\circ}$ C 80 % (up to 31 $^{\circ}$ C), decreasing lineally up to 50 % at 40 $^{\circ}$ C
MECHANICAL FEATURES Dimensions Weight	180 mm (W) x 95 mm (H) x 50 mm (D) 480 g.
ACCESSORIES	Mains power adapter, Car lighter adapter, F to BNC/DIN/F adapters, Mains cord, USB 2.0 connector cable, Rechargeable Li-Ion battery, Carrying suitcase, Carrying belt, Case (optional)

(*) Charging time estimated for a temperature range between 5 to 45 $^{\circ}$ C. Outside this range of temperatures, the charger will not initiate the charging process. At high ambient temperatures, the charging process will not be carried out in continuous mode because the charger circuit has a heat-protection device that disconnects this circuit when it is over 45 $^{\circ}$ C, returning to connect itself when it is above 40 $^{\circ}$ C.